

SERVICE MANUAL AND PARTS LIST

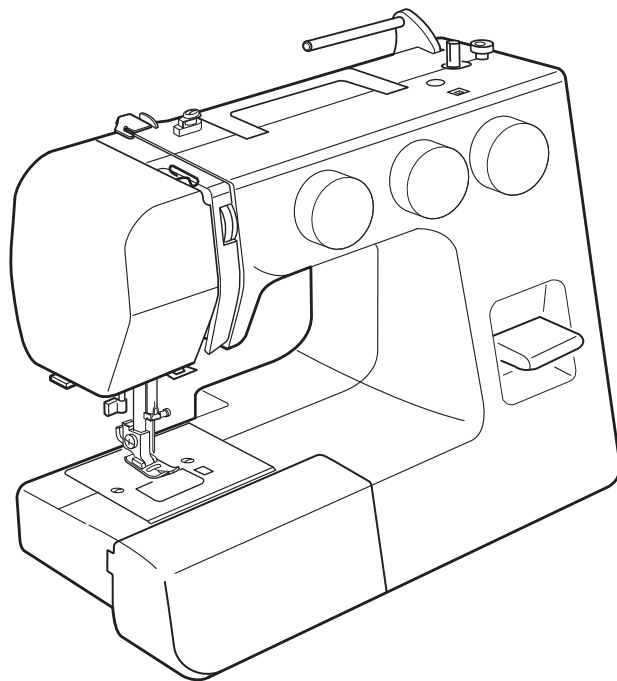

MODEL: E1019

CONTENTS

WHAT TO DO WHEN	1 - 3
SERVICE ACCESS	
FACE COVER	4
FRONT COVER	5
REAR COVER.....	6
MECHANICAL ADJUSTMENT	
TOP TENSION	7
PRESSER BAR HEIGHT AND ALIGNMENT	8
NEEDLE SWING.....	9
NEEDLE DROP POSITION	10
HOOK TIMING	11
NEEDLE BAR HEIGHT	12
ADJUSTING CLEARANCE BETWEEN NEEDLE AND HOOK POINT	13
FEED DOG HEIGHT	14
BACKLASH BETWEEN HOOK GEAR AND LOWER SHAFT GEAR...	15
DISTORTED PATTERN.....	16
BUTTONHOLE STITCH BALANCE	17
BARTACK FEED OF BUTTONHOLE.....	18
DISENGAGEMENT OF CAM FOLLOWER.....	19
MOTOR BELT TENSION.....	20
WIRING.....	21
PARTS LIST	22 - 37

WHAT TO DO WHEN

CONDITION	CAUSE	HOW TO FIX	REFERENCE
1. Skipped stitches	<ol style="list-style-type: none"> 1. Needle is not inserted properly. 2. Needle is bent or worn. 3. Incorrectly threaded. 4. Needle or thread are inappropriate for fabric being sewn. 5. Sewing on stretch fabric. 6. Presser foot pressure is too weak. 7. Inappropriate needle bar height. 8. Inappropriate needle to hook timing. 9. Inappropriate needle to hook clearance. 	<p>Insert the needle properly.</p> <p>Change the needle.</p> <p>Rethread.</p> <p>Use the recommended sewing needle and thread.</p> <p>Use a #11 blue tip needle.</p> <p>Adjust the presser bar level to make the pressure stronger.</p> <p>See mechanical adjustment "Needle Bar Height".</p> <p>See mechanical adjustment "Hook Timing".</p> <p>See mechanical adjustment "Adjusting Clearance Between Needle and Hook Point".</p>	<p>P.12</p> <p>P.11</p> <p>P.13</p>
2. Fabric not moving	<ol style="list-style-type: none"> 1. Incorrect feed dog height. 2. Feed dog is in down position. 3. Thread on bottom side of fabric is jammed up. 4. Feed dog teeth are worn. 	<p>See mechanical adjustment "Feed Dog Height".</p> <p>Raise the Feed dog level.</p> <p>Make sure to bring both needle and bobbin thread under the foot when starting sewing.</p> <p>Change the feed dog.</p>	<p>P.14</p>

CONDITION	CAUSE	HOW TO FIX	REFERENCE
3. Needle thread breaks	<ol style="list-style-type: none"> 1. Initial sewing speed is too fast. 2. Thread path is incorrect. 3. Needle is bent or dull. 4. Upper thread tension is too strong. 5. Needle size is inappropriate for fabric. 6. Needle eye is worn. 7. Needle hole in needle plate is worn or burred. 	<p>Start with medium speed.</p> <p>Use the proper thread path.</p> <p>Replace with a new needle.</p> <p>Adjust needle thread tension correctly.</p> <p>Use appropriate needle for fabric and thread in use.</p> <p>Change the needle.</p> <p>Repair the hole or replace the needle plate.</p>	
4. Bobbin thread breaks	<ol style="list-style-type: none"> 1. Incorrectly threaded bobbin. 2. Too much thread is on the bobbin. 3. Lint is stuck inside the bobbin holder. 4. Thread quality is too low. 5. Thread is jamming around the bobbin. 	<p>Thread bobbin correctly.</p> <p>Adjust the position of stopper.</p> <p>Clean the shuttle.</p> <p>Change to a higher quality sewing thread.</p> <p>Clear out the jamming thread.</p>	
5. Needle breaks	<ol style="list-style-type: none"> 1. Needle is hitting the needle plate. 2. Needle is bent or worn. 3. Needle is hitting the Hook. 4. The fabric moves while the needle is piercing it, or the needle zigzags while in fabric. 5. Fabric is being pulled too strongly while sewing. 	<p>See mechanical adjustment "Needle Drop Position".</p> <p>Change the needle.</p> <p>See mechanical adjustment "Clearance between Needle and Hook Point".</p> <p>See mechanical adjustment "Needle Swing".</p> <p>Guide the fabric gently while sewing.</p>	<p>P.10</p> <p>P.13</p> <p>P.9</p>

CONDITION	CAUSE	HOW TO FIX	REFERENCE
6. Noisy operation	1. Backlash between the hook gear and lower shaft gear is too great.	See mechanical adjustment "Backlash between Hook Gear and Lower Shaft Gear".	P.15
	2. Lower shaft gear is loose.	Eliminate the looseness.	
	3. Inappropriate belt tension.	See mechanical adjustment "Motor Belt Tension."	P.20
	4. Not enough oil.	Oil all moving parts.	
	5. Upper shaft is loose.	Eliminate the looseness.	
7. Deformed pattern	1. Inappropriate feed balance.	See mechanical adjustment "Distorted pattern"	P.16
	2. Inappropriate zigzag synchronization.	See mechanical adjustment "Needle Swing."	P.9
	3. Upper thread tension is too strong.	Adjust needle thread tension correctly.	
8. Improper buttonhole results	1. Buttonhole stitch balance is not correct.	See mechanical adjustment "Buttonhole Stitch Balance".	P.17
	2. Changing to bar tack is too early or will not work.	See mechanical adjustment "Bartack Feed of Buttonhole".	P.18
9. Improper pattern	1. The pattern selector is blocked.	See mechanical adjustment "Disengagement of Cam Follower".	P.19
	2. The pattern selector will not select the correct pattern.	See mechanical adjustment "Disengagement of Cam Follower".	P.19

SERVICE ACCESS

FACE COVER

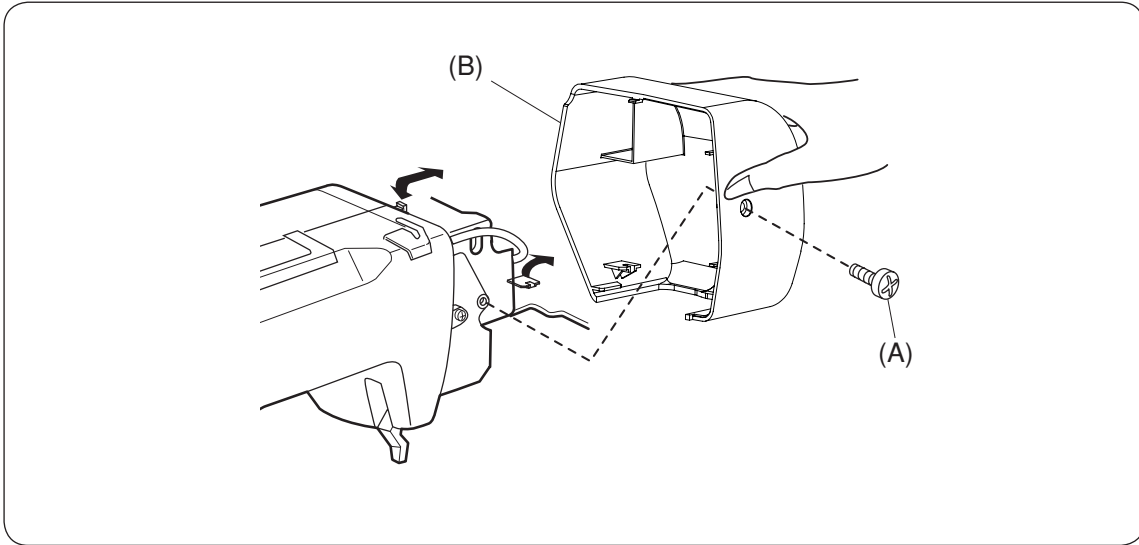

TO REMOVE:

1. REMOVE THE SETSCREWS (A).
2. TAKE THE FACE COVER (B) OFF.

TO ATTACH:

1. FOLLOW THE ABOVE PROCEDURE IN REVERSE.

SERVICE ACCESS

FACE COVER

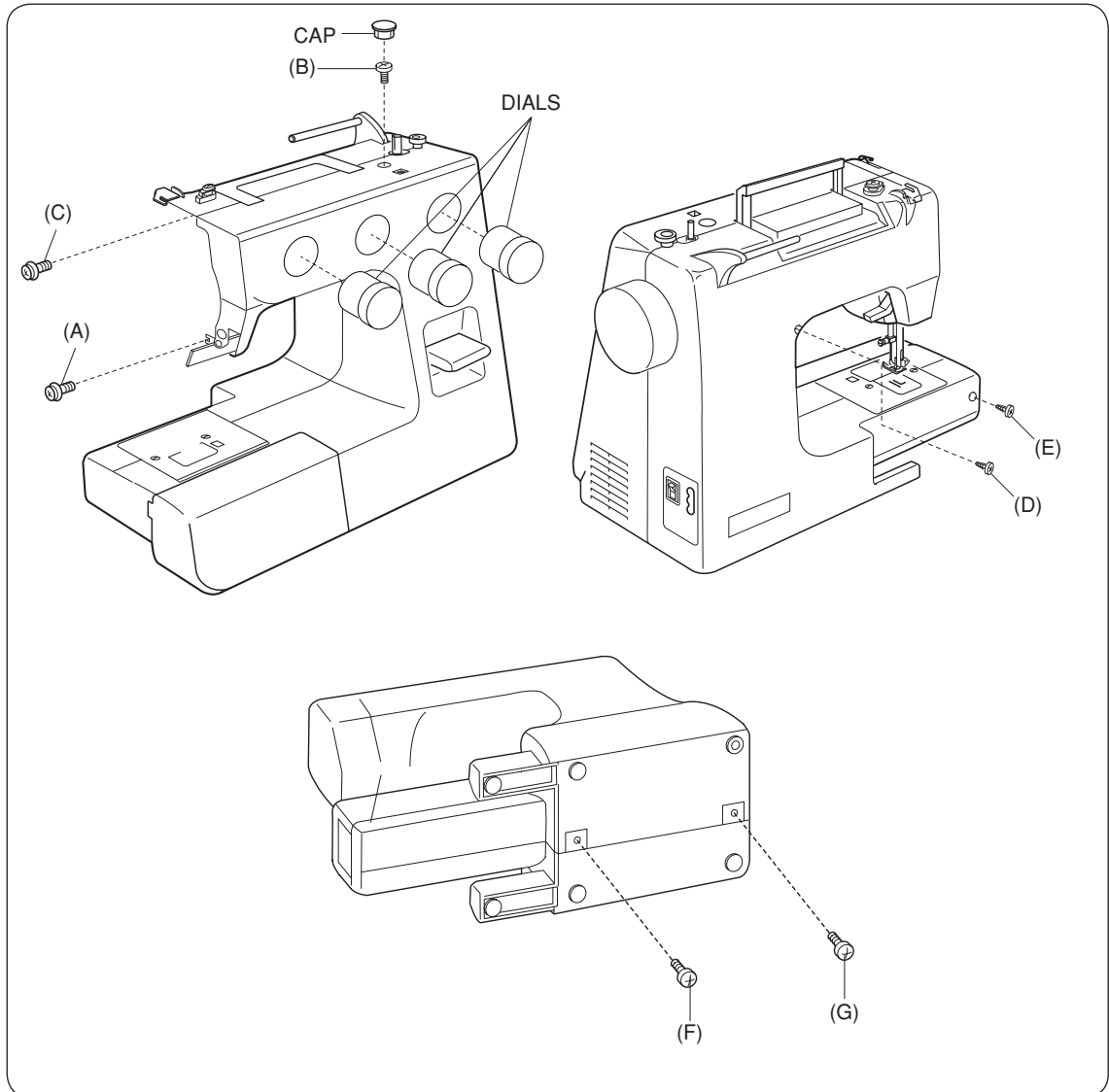

TO REMOVE:

1. REMOVE THE FACE COVER (SEE PAGE 4), AND EXTENSION TABLE.
REMOVE THE CAP, SETSCREWS (B), (D), (E), (F), (G) AND DIALS.
LOOSEN THE SETSCREW (A), (C).
REMOVE THE FRONT COVER.

TO ATTACH:

2. FOLLOW THE ABOVE PROCEDURE IN REVERSE.

SERVICE ACCESS

REAR COVER

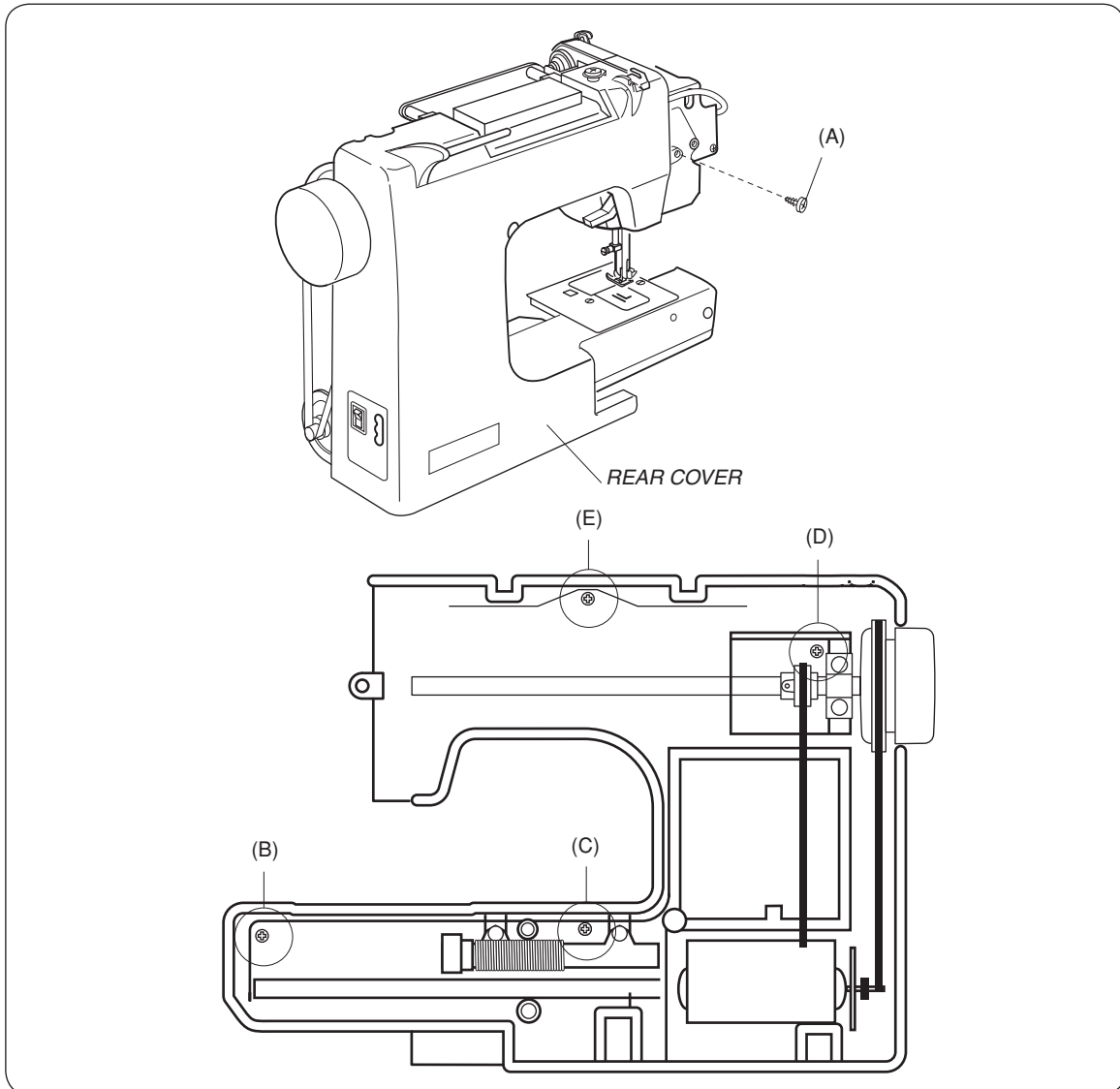

TO REMOVE

1. REMOVE THE FACE COVER AND FRONT COVER. (SEE PAGE 4, 5)
2. REMOVE THE SETSCREWS (A), (B), (C), (D) AND (E).
3. LOWER THE PRESSER FOOT LIFTER. REMOVE THE REAR COVER.

TO ATTACH

4. FOLLOW THE ABOVE PROCEDURE IN REVERSE.

MECHANICAL ADJUSTMENT

TOP TENSION

TO CHECK:

THE STANDARD UPPER THREAD TENSION SHOULD BE 75 - 90g WHEN PULLING THE THREAD (COTTON THREAD #50) IN THE DIRECTION OF (B) WITH SETTING THE TENSION DIAL AT "4". (MAKE SURE THE FOOT SHOULD BE LOWERED.)
IF THE TENSION IS OUT OF THE STANDARD RANGE, ADJUST IT AS FOLLOWS:

ADJUSTMENT PROCEDURE:

1. REMOVE THE FACE COVER AND FRONT COVER. (SEE PAGE 4, 5.)
2. TURN THE ADJUSTING NUT (C) IN THE DIRECTION OF (D) WHEN THE UPPER THREAD TENSION IS TOO TIGHT.
TURN THE ADJUSTING NUT (C) IN THE DIRECTION OF (E) WHEN THE UPPER THREAD TENSION IS TOO LOOSE.
3. ATTACH THE FRONT COVER AND FACE COVER.

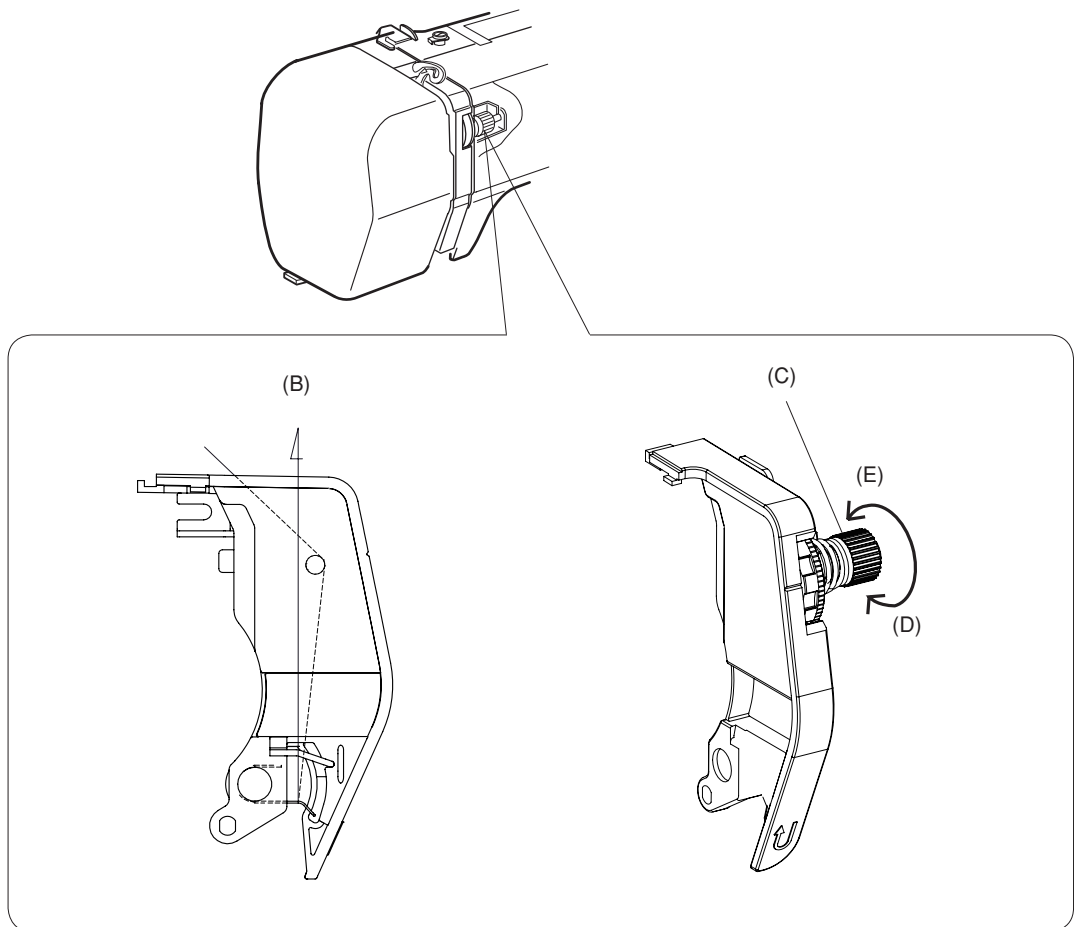

MECHANICAL ADJUSTMENT

PRESSER BAR HEIGHT AND ALIGNMENT

TO CHECK:

1. RAISE THE PRESSER FOOT LIFTER (A).
2. THE DISTANCE BETWEEN THE PRESSER FOOT (D) AND THE NEEDLE PLATE (E) SHOULD BE 6.0MM (0.24").

ADJUSTMENT PROCEDURE:

1. REMOVE THE FACE COVER. (SEE PAGE 4.)
2. REMOVE THE SCREW (B) AND TAKE THE LED ARM OFF.
3. RAISE THE PRESSER FOOT LEVER AND LOOSEN THE SCREW (C) ON THE PRESSER BAR HOLDER.
ADJUST THE DISTANCE BETWEEN THE PRESSER FOOT (D) AND THE NEEDLE PLATE (E) TO 6.0MM (0.24").
4. TIGHTEN THE SCREW (C) SECURELY.
5. TIGHTEN THE SCREW (B) TO SECURE THE LED ARM.
6. ATTACH THE FACE COVER.

NOTE: WHEN YOU TIGHTEN THE SCREW (C), MAKE SURE THAT BOTH SIDES OF THE PRESSER FOOT ARE PARALLEL TO THE FEED DOG SLOTS (F) ON THE NEEDLE PLATE.

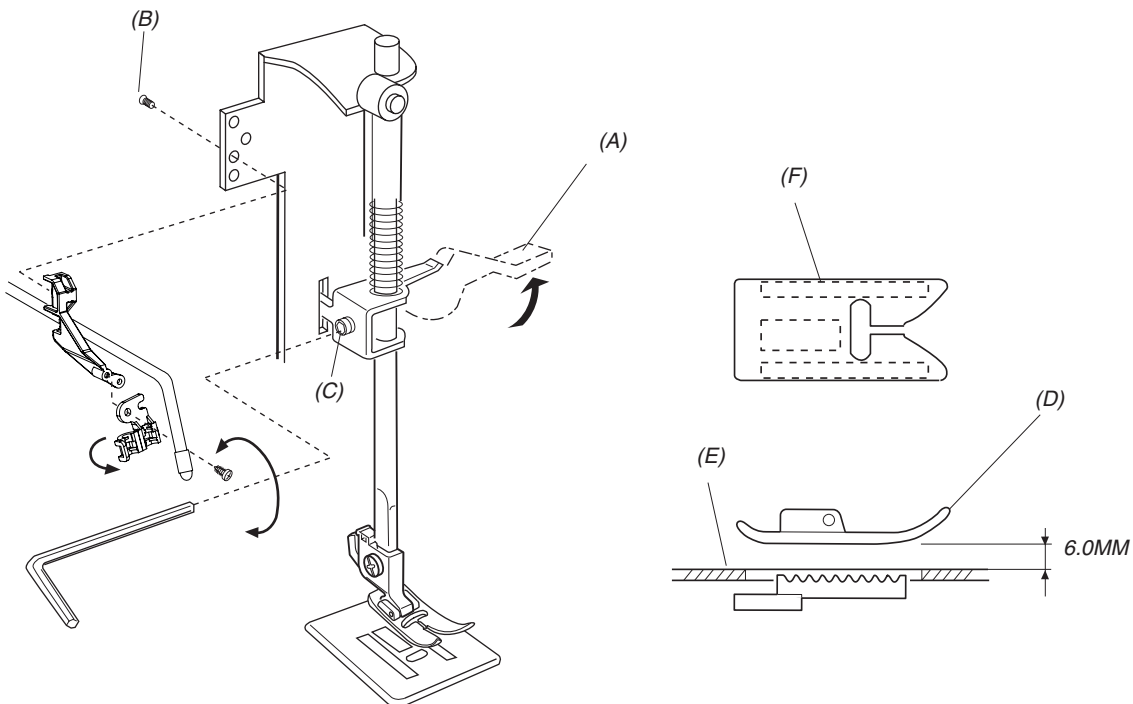

MECHANICAL ADJUSTMENT

NEEDLE SWING

TO CHECK:

ADJUST THE NEEDLE SWING ACCORDING TO THE FOLLOWING PROCEDURE, IF THE NEEDLE BAR STARTS MOVING SIDWAYS WHILE THE NEEDLE IS IN THE FABRIC AT SEWING THE ZIGZAG PATTERN (WITH MAXIMUM ZIGZAG WIDTH).

ADJUSTMENT PROCEDURE:

1. SET THE PATTERN SELECTOR DIAL WITH MAXIMUM ZIGZAG WIDTH, AND REMOVE THE FRONT COVER. (SEE PAGE 5.)
2. LOOSEN TWO SET SCREWS.
3. ADJUST THE NEEDLE SWING BY TURNING THE HANDWHEEL, WHILE HOLDING THE WORM SO AS NOT TO ROTATE IT, UNTIL THE NEEDLE SWING STARTS AT 2 - 3MM ON THE NEEDLE PLATE AFTER THE NEEDLE HAS COME OUT OF THE RIGHT SIDE OF THE NEEDLE HOLE.
4. TIGHTEN TWO SET SCREWS.
5. ATTACH THE FRONT COVER.

NOTE: AFTER ADJUSTING THE NEEDLE SWING, CHECK THAT THE UPPER SHAFT WORM AND GEAR ROTATE SMOOTHLY WITHOUT ANY BACKLASH BETWEEN THEM.

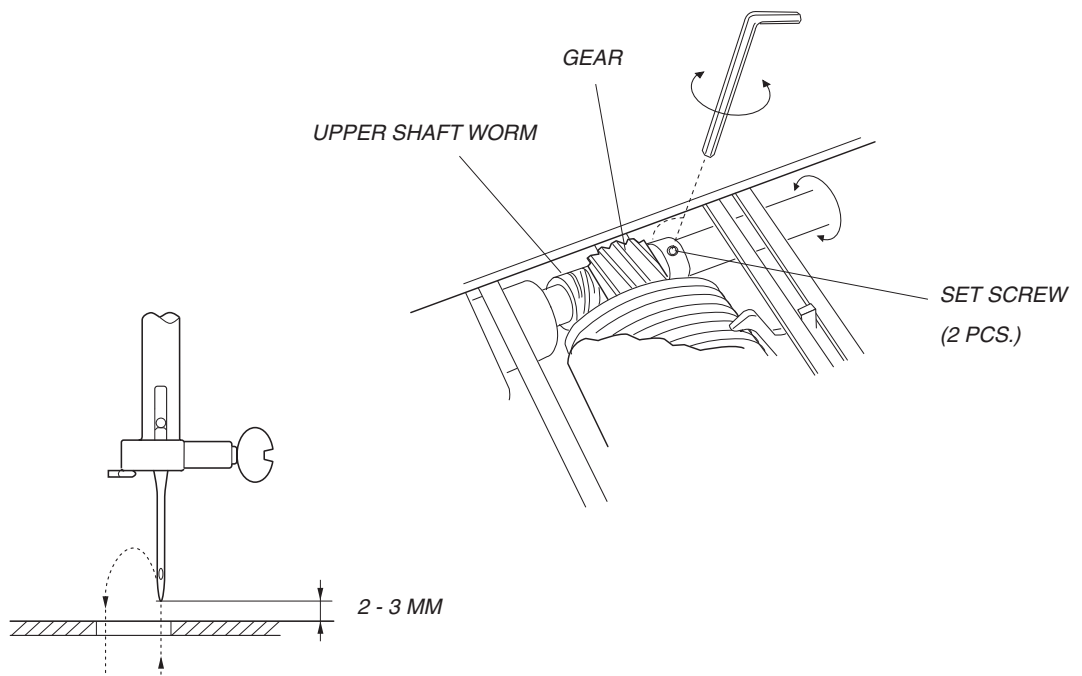

MECHANICAL ADJUSTMENT

NEEDLE DROP POSITION

SET THE SELECTOR DIAL AT STRAIGHT STITCH.

THE NEEDLE DROP POSITION SHOULD BE THE CENTER OF THE NEEDLE PLATE HOLE.

SET THE SELECTOR DIAL AT ZIGZAG STITCH WITH MAXIMUM ZIGZAG WIDTH.

THE CLEARANCE BETWEEN THE NEEDLE DROP POSITION AND THE EDGE OF NEEDLE PLATE HOLE SHOULD BE 0.2 MM OR MORE FOR BOTH SIDE.

IF NOT, MAKE ADJUSTMENT AS FOLLOWS:

ADJUSTMENT PROCEDURE:

1. REMOVE THE FACE COVER (SEE PAGE 4).
2. SET THE PATTERN SELECTOR DIAL AT ZIGZAG STITCH WITH MAXIMUM WIDTH.
3. LOOSEN THE SETSCREW.
MOVE THE NEEDLE BAR SUPPORTER TO ADJUST THE NEEDLE DROP POSITION IN THE CENTER OF THE NEEDLE HOLE.
4. ATTACH THE FACE COVER.

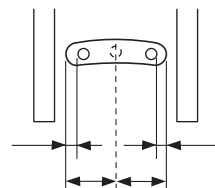
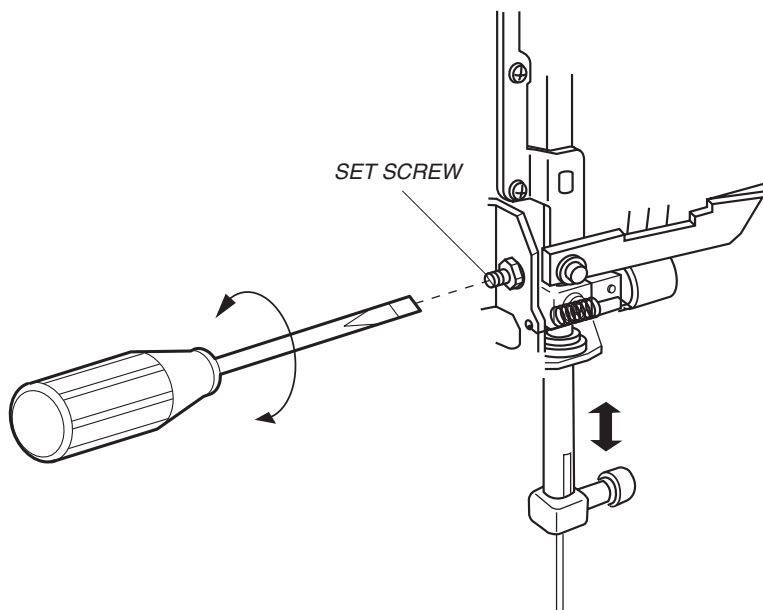

BOTH CLEARANCE SHOULD BE EQUAL

MECHANICAL ADJUSTMENT

HOOK TIMING

SET THE PATTERN SELECTOR DIAL AT ZIGZAG STITCH WITH MAXIMUM ZIGZAG WIDTH. THE AMOUNT OF ASCENDING TRAVEL OF THE NEEDLE BAR FROM ITS LOWER POSITION TO THE POSITION WHERE THE TIP OF THE ROTARY HOOK EXACTLY MEETS THE RIGHT SIDE OF THE NEEDLE SHOULD BE 1.4 - 2.0 MM.

1. SET THE PATTERN SELECTOR DIAL AT MAXIMUM ZIGZAG WIDTH. BRING THE NEEDLE AT RIGHT LOWEST NEEDLE POSITION.
2. REMOVE THE SETSCREW ON THE NEEDLE PLATE, THE NEEDLE PLATE AND THE BOBBIN HOLDER.
3. LOOSEN THE HEXAGONAL SOCKET SCREWS ON THE LOWER SHAFT GEAR.
4. TURN THE HANDWHEEL TOWARD YOU TO RAISE THE NEEDLE BAR 1.7 MM FROM ITS RIGHT LOWEST POSITION.
5. WHILE HOLDING THE HANDWHEEL TO PREVENT THE NEEDLE BAR FROM MOVING, TURN THE LOWER SHAFT GEAR IN THE DIRECTION OF ARROW UNTIL THE TIP OF THE ROTARY HOOK EXACTLY MEETS THE RIGHT SIDE OF THE NEEDLE.
6. TIGHTEN THE HEXAGONAL SOCKET SCREWS ON THE LOWER SHAFT GEAR.
7. ATTACH THE BOBBIN HOLDER, NEEDLE PLATE.

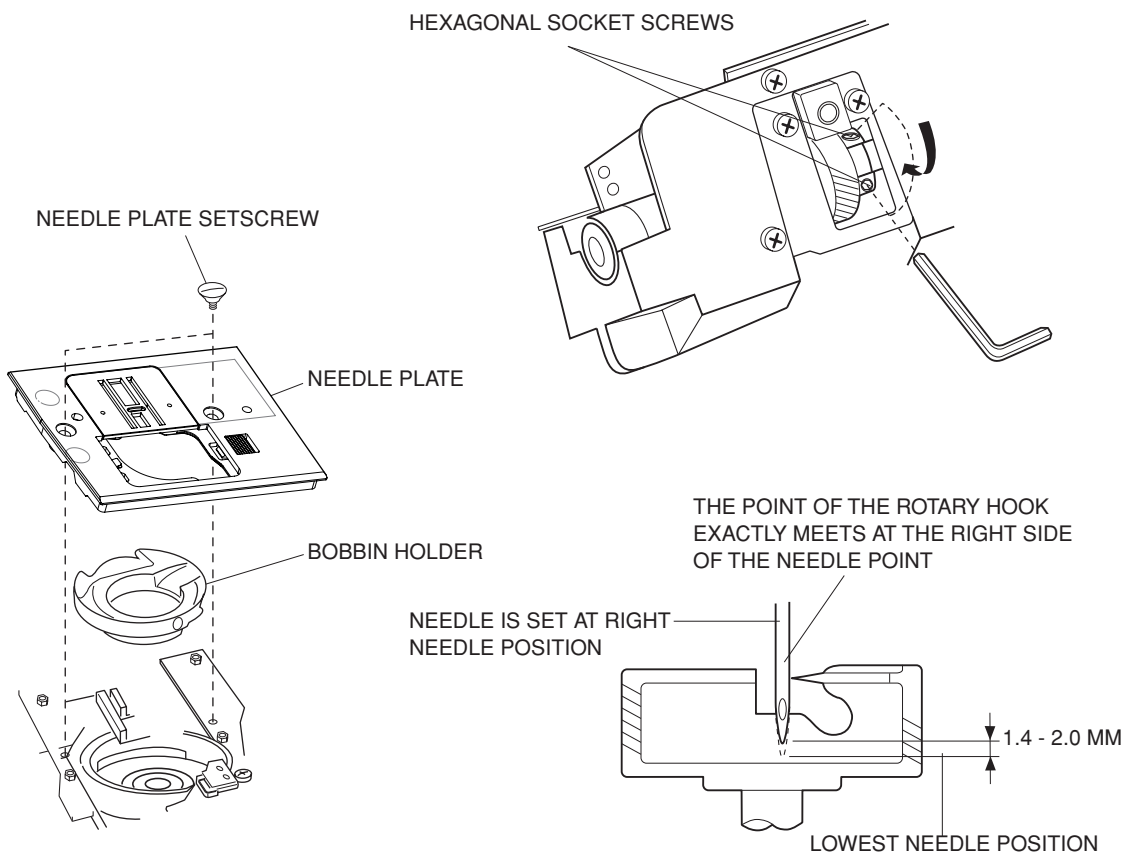

MECHANICAL ADJUSTMENT

NEEDLE BAR HEIGHT

TO CHECK:

THE STANDARD DISTANCE BETWEEN THE UPPER EDGE OF THE NEEDLE EYE AND THE UPPER SURFACE OF THE HOOK RACE SHOULD BE IN THE RANGE OF 3.0 - 3.6 MM WHEN THE HOOK POINT MEETS THE RIGHT SIDE OF THE NEEDLE IN ITS ASCENDING TRAVEL FROM THE RIGHT LOWEST POSITION OF THE MAXIMUM WIDTH ZIGZAG STITCH.

ADJUSTMENT PROCEDURE:

1. SELECT THE ZIGZAG STITCH WITH MAXIMUM STITCH WIDTH.
BRING THE NEEDLE TO THE RIGHT LOWEST POSITION.
2. REMOVE THE FACE COVER, FRONT COVER AND REAR COVER. (SEE PAGE 4 - 6).
3. REMOVE THE NEEDLE PLATE AND BOBBIN HOLDER.
4. TURN THE HANDWHEEL TOWARD YOU UNTIL THE HOOK POINT MEETS THE RIGHT SIDE OF THE NEEDLE.
5. LOOSEN THE SETSCREW AND MOVE THE NEEDLE BAR UP OR DOWN TO ADJUST THE NEEDLE HEIGHT.

NOTE: BE CAREFUL NOT TO ROTATE THE NEEDLE BAR.

6. TIGHTEN THE SETSCREW.
7. ATTACH THE BOBBIN HOLDER, NEEDLE PLATE AND FACE COVER.

NOTE: BEFORE PERFORMING THIS ADJUSTMENT, CHECK THE NEEDLE TO HOOK TIMING.

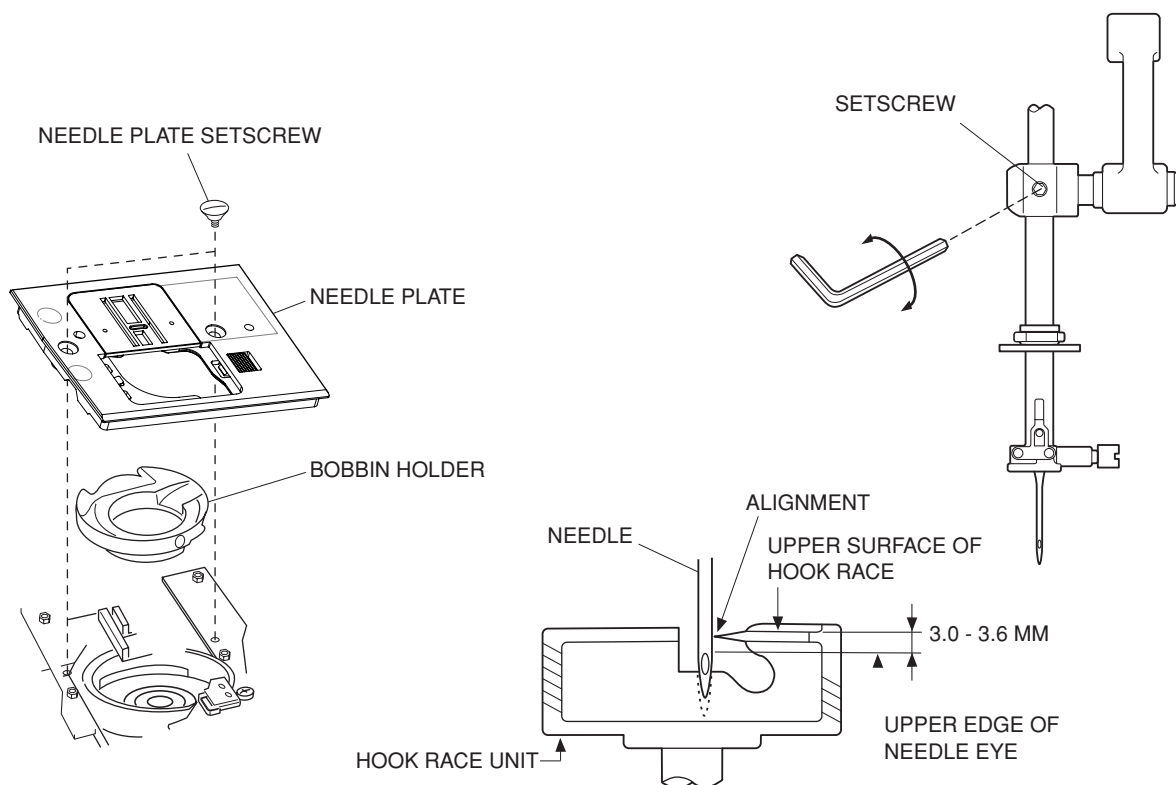

MECHANICAL ADJUSTMENT

ADJUSTING CLEARANCE BETWEEN NEEDLE AND HOOK POINT

THE STANDARD CLEARANCE BETWEEN THE NEEDLE AND HOOK POINT SHOULD BE $-0.10 - + 0.05$ MM.

TO ADJUST:

1. REMOVE THE FACE COVER (SEE PAGE 4).
2. SELECT THE ZIGZAG STITCH WITH MAXIMUM STITCH WIDTH. BRING THE NEEDLE TO THE RIGHT POSITION.
3. REMOVE THE NEEDLE PLATE AND BOBBIN HOLDER. REPLACE THE NEEDLE WITH THE TEST PIN AND TIGHTEN THE NEEDLE CLAMP SCREW.
4. LOOSEN THE SETSCREWS A(2 PCS) AND MOVE THE PRESSER BAR BASE PLATE IN THE DIRECTION OF THE ARROWS (C OR B). THE CLEARANCE BETWEEN THE NEEDLE AND HOOK SHOULD BE $-0.10 - +0.05$ MM. TIGHTEN THE SCREWS.
 - MOVE THE PRESSER BAR BASE PLATE IN THE DIRECTION OF B WHEN THE CLEARANCE IS TOO LARGE.
 - MOVE THE PRESSER BAR BASE PLATE IN THE DIRECTION OF C WHEN THE CLEARANCE IT TOO SMALL.
 - * THE EDGE OF PRESSER BAR BASE PLATE SHOULD ALWAYS TOUCHES THE BOSSES WHILE ADJUSTING THE CLEARANCE IT.
5. ATTACH THE FACE COVER.

NOTE: AFTER THIS ADJUSTMENT, CHECK IF THE CLEARANCE BETWEEN NEEDLE AND NEEDLE PLATE IS MORE THAN 0.15MM AS SHOWN.

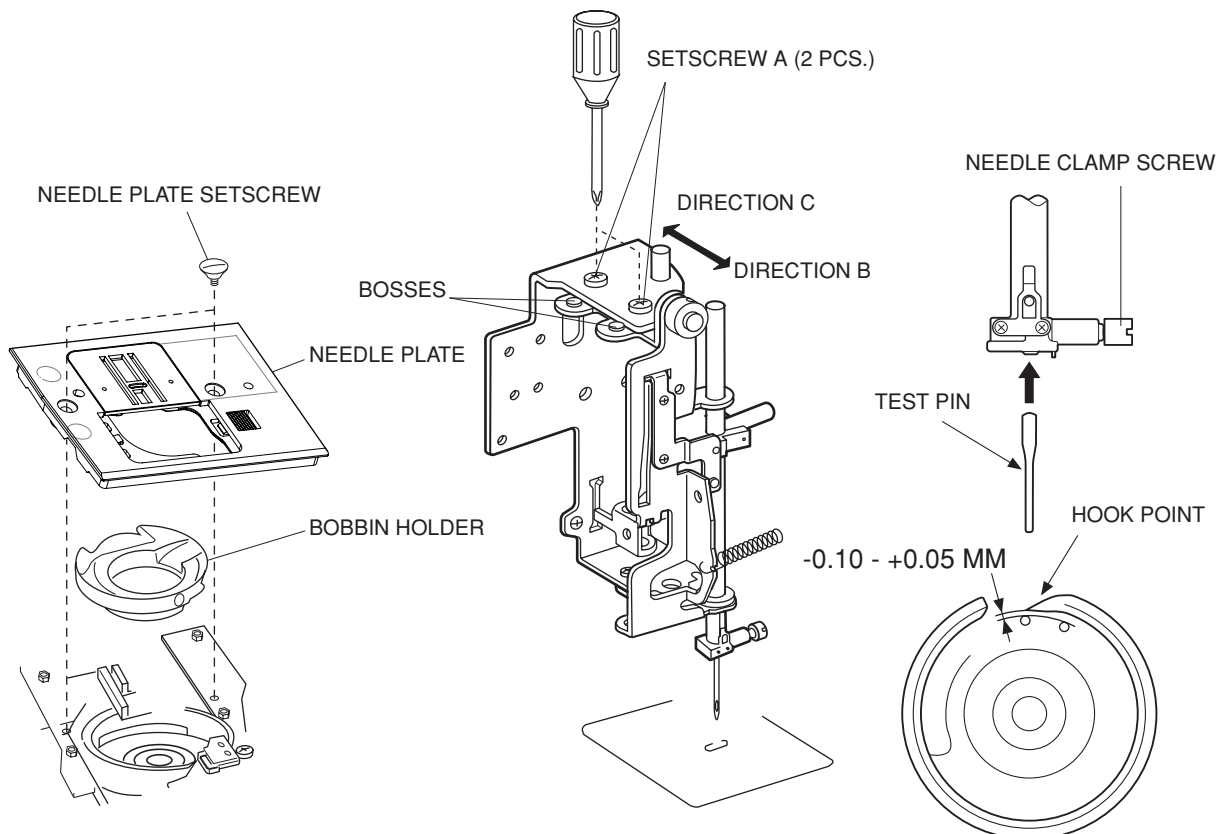

MECHANICAL ADJUSTMENT

FEED DOG HEIGHT

TO CHECK:

1. LOWER THE PRESSER FOOT.
 2. TURN THE HANDWHEEL TOWARD YOU UNTIL THE FEED DOG COMES TO ITS HIGHEST POSITION. THE DISTANCE BETWEEN THE FEED DOG AND THE UPPER SURFACE OF THE NEEDLE PLATE SHOULD BE 0.8 - 0.95 MM.
- IF IT IS NOT IN THE RANGE, ADJUST AS FOLLOWS.

ADJUSTMENT PROCEDURE:

1. SELECT THE STRAIGHT STITCH.
2. LOOSEN THE SCREW (A) .
3. TURN THE HANDWHEEL TO BRING THE FEED DOG TO ITS HIGHEST POSITION.
4. IF THE FEED DOG HEIGHT IS LOWER THAN 0.8 MM: TURN ADJUSTING SCREW (B) IN THE DIRECTION OF (C).
5. IF THE FEED DOG HEIGHT IS HIGHER THAN 0.95 MM: TURN THE ADJUSTING SCREW (B) IN THE DIRECTION OF (D).
6. TIGHTEN THE SETSCREW (A).

UPPER SURFACE OF
THE NEEDLE PLATE

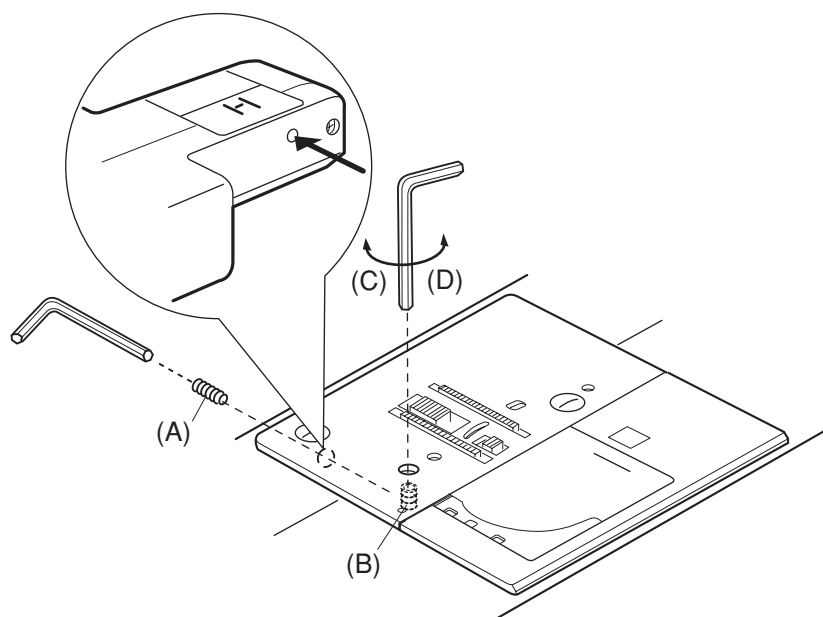
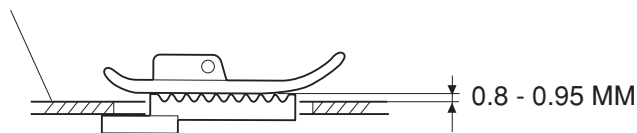

MECHANICAL ADJUSTMENT

BACKLASH BETWEEN HOOK GEAR AND LOWER SHAFT GEAR

TO CHECK:

1. THE ROTARY PLAY OF THE HOOK POINT SHOULD BE 0.8 MM OR LESS WHEN IT IS IN BETWEEN THE SPAN OF THE FEED DOG TEETH, AND THE GEARS SHOULD TURN SMOOTHLY.

ADJUSTMENT PROCEDURE:

1. REMOVE THE NEEDLE PLATE AND BOBBIN HOLDER.
2. REMOVE THE FRONT COVER (SEE PAGE 5.)
3. LOOSEN THE SETSCREW (E).
4. IF THE ROTARY PLAY IS TOO LARGE, TURN THE LOWER SHAFT BUSHING IN THE DIRECTION OF (C).
5. IF THE ROTARY PLAY IS TOO SMALL, TURN THE LOWER SHAFT BUSHING IN THE DIRECTION OF (D).
6. TIGHTEN THE SETSCREW (E).
7. ATTACH THE FRONT COVER.
8. ATTACH THE BOBBIN HOLDER AND NEEDLE PLATE.

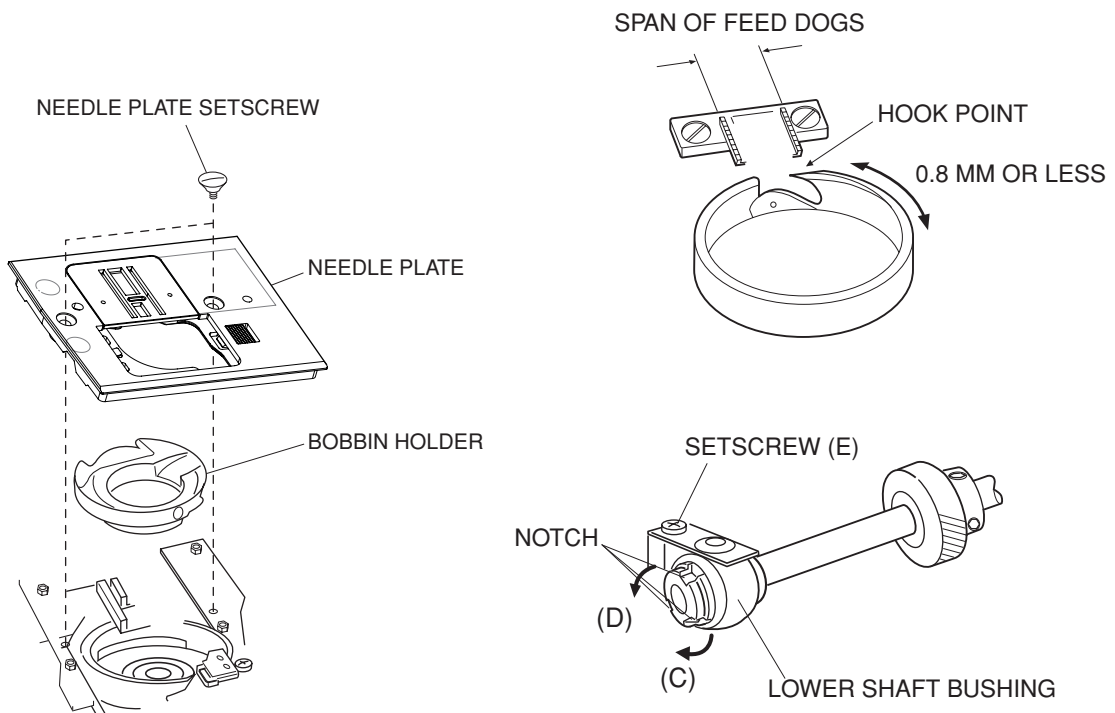

MECHANICAL ADJUSTMENT

DISTORTED PATTERN

TO CHECK:

IF THE STRETCH STITCH PATTERNS ARE DISTORTED WITH SETTING THE STITCH LENGTH CONTROL AT "S.S.".

(IN CASE OF BEING A DIFFERENCE BETWEEN FORWARD FEEDING AND BACKWARD FEEDING DURING STRETCH STITCH PATTERNS), MAKE AN ADJUSTMENT AS FOLLOWS:

ADJUSTMENT PROCEDURE:

1. RAISE THE CARRYING HANDLE.
2. SET THE PATTERN SELECTOR CONTROL AT "A ", AND THE STITCH LENGTH CONTROL AT "S.S.".
3. TURN THE STRETCH STITCH ADJUSTING SCREW IN THE DIRECTION OF (C) WHEN $A > B$, OR IN THE DIRECTION OF (D) WHEN $A < B$.

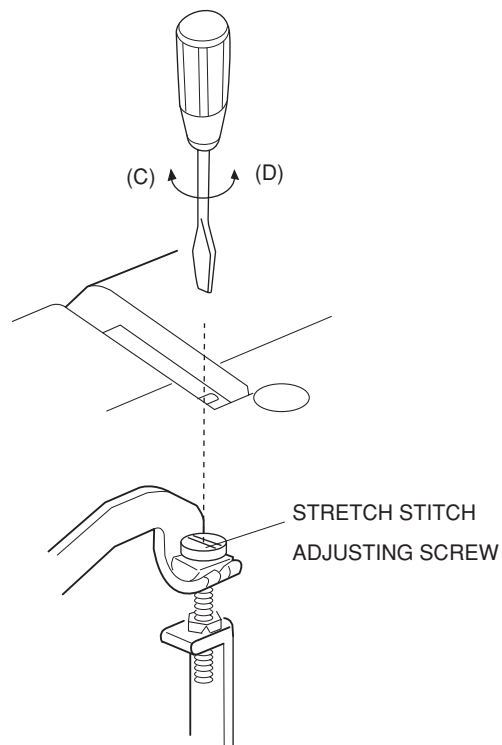
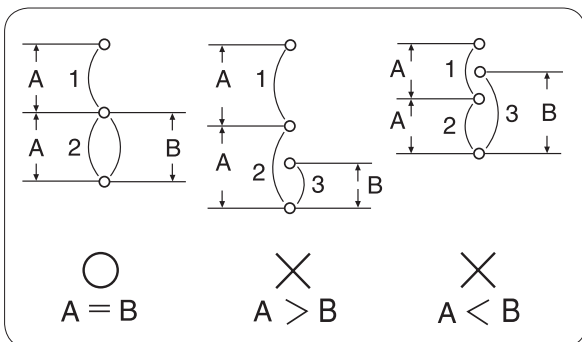

MECHANICAL ADJUSTMENT

BUTTONHOLE STITCH BALANCE

WHEN SEWING BUTTONHOLES, THE STITCHES ON EACH SIDE OF THE BUTTONHOLE SHOULD HAVE THE SAME STITCH DENSITY.

THE RANGE OF 9 - 11 STITCHES IN THE RIGHT SIDE ROW AGAINST 10 STITCHES IN THE LEFT SIDE ROW CONSIDERED ACCEPTABLE.

1. SEW A BUTTONHOLE AND CHECK BOTH RIGHT AND LEFT ROW STITCH DENSITIES.
2. IF THE LEFT SIDE ROW IS DENSER THAN THE RIGHT SIDE ROW (A), TURN THE ADJUSTING SCREW COUNTERCLOCKWISE (IN THE DIRECTION OF C).
IF THE RIGHT SIDE ROW IS DENSER THAN THE LEFT SIDE ROW (B), TURN THE ADJUSTING SCREW CLOCKWISE (IN THE DIRECTION OF D).

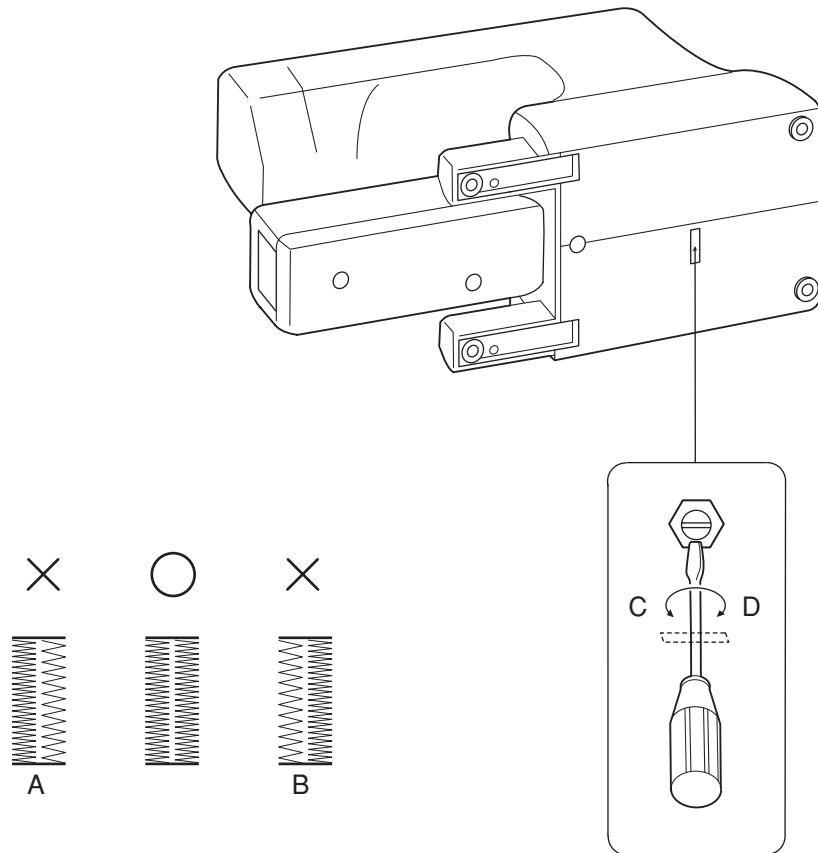

MECHANICAL ADJUSTMENT

BARTACK FEED OF BUTTONHOLE

TO CHECK:

IF THE MATERIAL IS FEED FORWARD OR BACKWARD WHEN SEWING BARTACK ON BUTTONHOLE, MAKE AN ADJUSTMENT AS FOLLOWS:

ADJUSTMENT PROCEDURE:

1. SET THE PATTERN SELECTOR CONTROL AT “” AND THE STITCH LENGTH CONTROL AT “4”.
2. REMOVE THE FRONT COVER. (SEE PAGE 5.)
3. PLACE A PIECE OF PAPER UNDER THE FOOT AND TURN THE HANDWHEEL. IF THE PAPER IS FED FORWARD, TURN THE ADJUSTING SCREW IN THE DIRECTION OF (C). IF THE PAPER IS FED BACKWARD, TURN THE ADJUSTING SCREW IN THE DIRECTION OF (D).
4. MOUNT THE FRONT COVER.

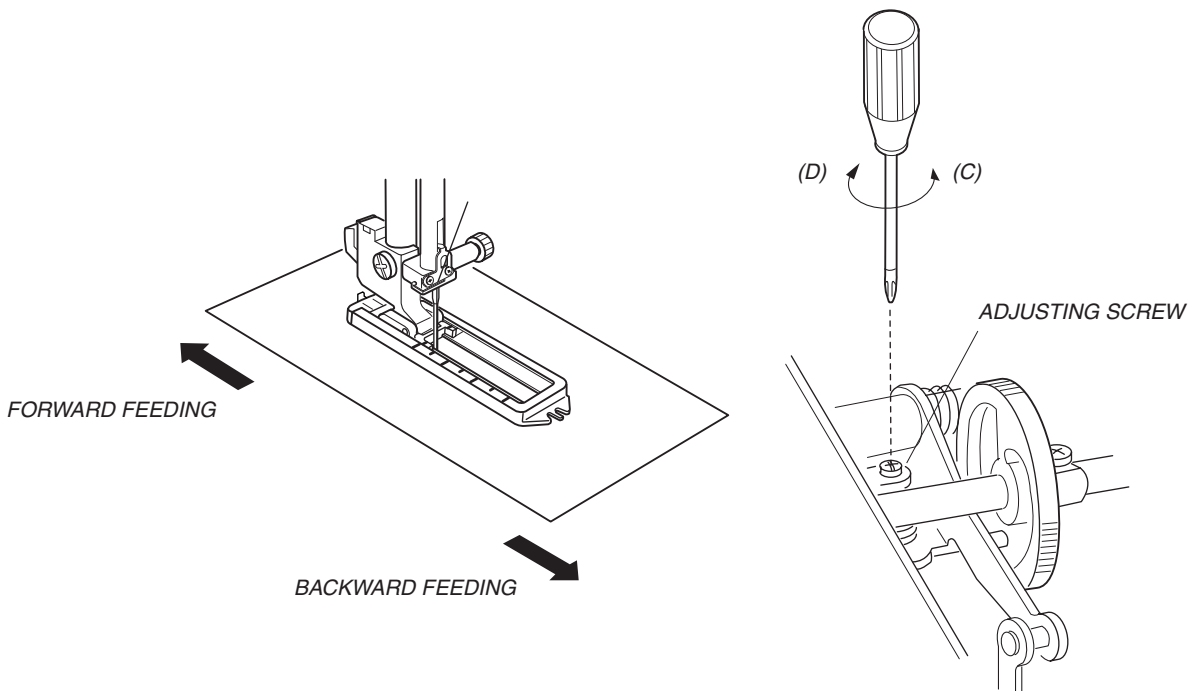

MECHANICAL ADJUSTMENT

DISENGAGEMENT OF CAM FOLLOWER

TO CHECK:

IF THE CLEARANCE BETWEEN THE CAM FOLLOWER AND THE TOP CONVEX OF THE ZIGZAG CAM IS NOT ENOUGH, THE PATTERN SELECTOR DIAL IS BLOCKED OR WILL NOT SELECT THE CORRECT PATTERN.

ADJUSTMENT PROCEDURE:

1. REMOVE THE FRONT COVER (SEE PAGE 5).
2. SET THE PATTERN SELECTOR DIAL AT PATTERN " A C D".
3. PUT THE CAM FOLLOWER TO THE ZIGZAG CAM AND PUT THE CAM FOLLOWER RELEASING ARM TO THE PATTERN SELECTOR CAM.
4. LOOSEN THE SET SCREW.
5. PUSH THE CONVEX PART OF THE CAM FOLLOWER RELEASING ARM IN THE DIRECTION OF ARROW UNTIL THE CAM FOLLOWER RELEASING ARM TOUCHES POSITION (A) OF THE PATTERN SELECTOR CAM, AND THEN, TIGHTEN THE SETSCREW.

NOTE: AFTER THIS ADJUSTMENT, CHECK THAT THE CLEARANCE BETWEEN THE ZIGZAG CAM AND THE CAM FOLLOWER IS ABOUT 0.3 MM WHEN SETTING THE CAM FOLLOWER RELEASING ARM ONTO POSITION (B) OF PATTERN SELECTOR CAM.

6. MOUNT THE FRONT COVER.

NOTE: CHECK THE NEEDLE MOVEMENT FOR STRAIGHT STITCH.

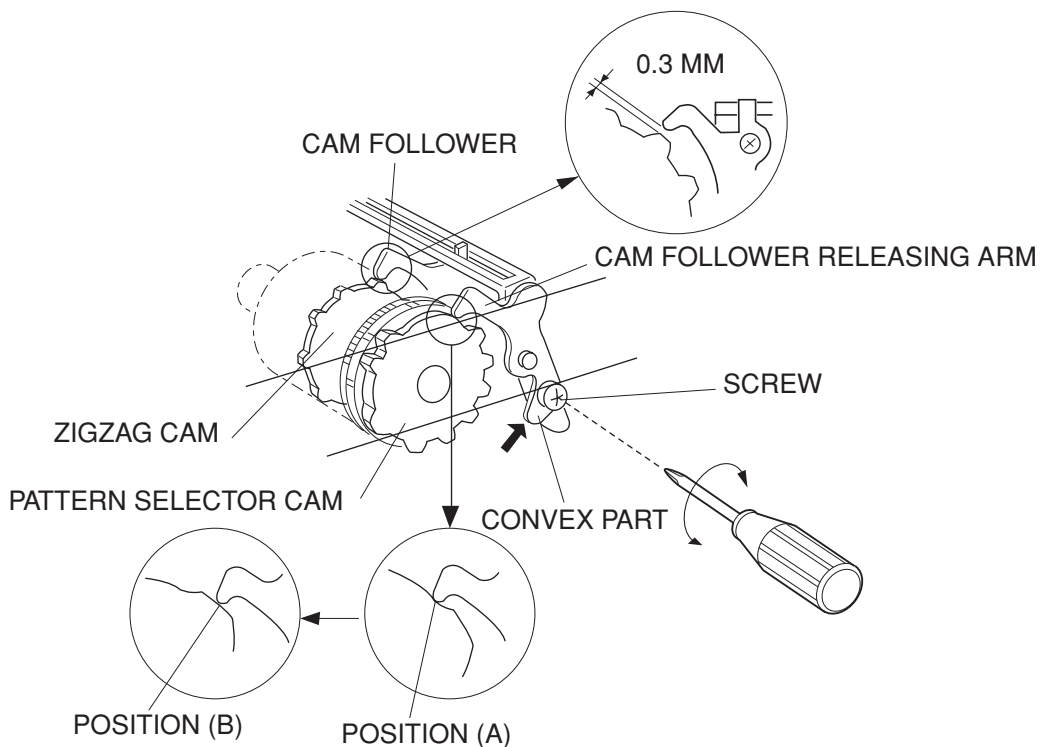

MECHANICAL ADJUSTMENT

MOTOR BELT TENSION

TO CHECK:

1. IF THE MOTOR BELT TENSION IS TOO TIGHT OR TOO LOOSE, IT CAN CAUSE A BELT NOISE: IF THE TENSION IS TOO TIGHT, IT CAN CAUSE THE MACHINE TO RUN SLOWLY AND THE MOTOR TO OVERLOAD; IF THE TENSION IS TOO LOOSE; IT CAN CAUSE THE BELT TEETH ON THE MOTOR PULLEY TO JUMP.
2. THE CORRECT MOTOR BELT TENSION IS WHEN THE DEFLECTION OF MOTOR BELT IS ABOUT 7MM (0.28") - 9MM (0.36"). (WHEN PUSHING THE MOTOR BELT BY FINGER WITH A 300 GRAM FORCE.)

ADJUSTMENT PROCEDURE:

1. REMOVE THE REAR COVER. (SEE PAGE 6)
2. LOOSEN THE SCREWS (A) AND (B).
3. MOVE THE MOTOR UP OR DOWN TO ADJUST THE DEFLECTION ABOUT 7MM (0.28") - 9MM (0.36").
4. TIGHTEN THE SCREWS (A) AND (B).

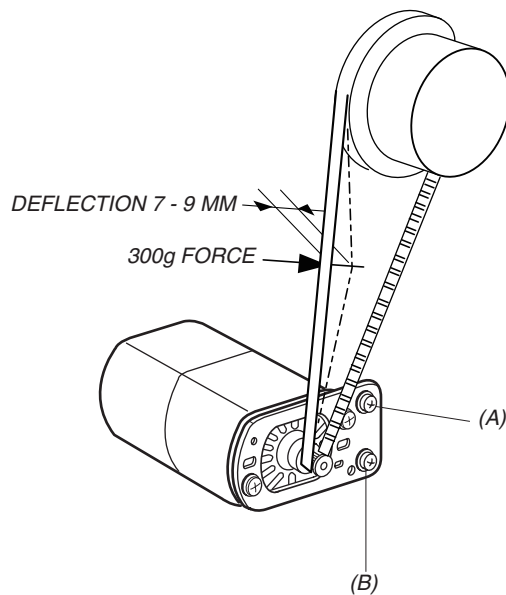

PARTS LIST

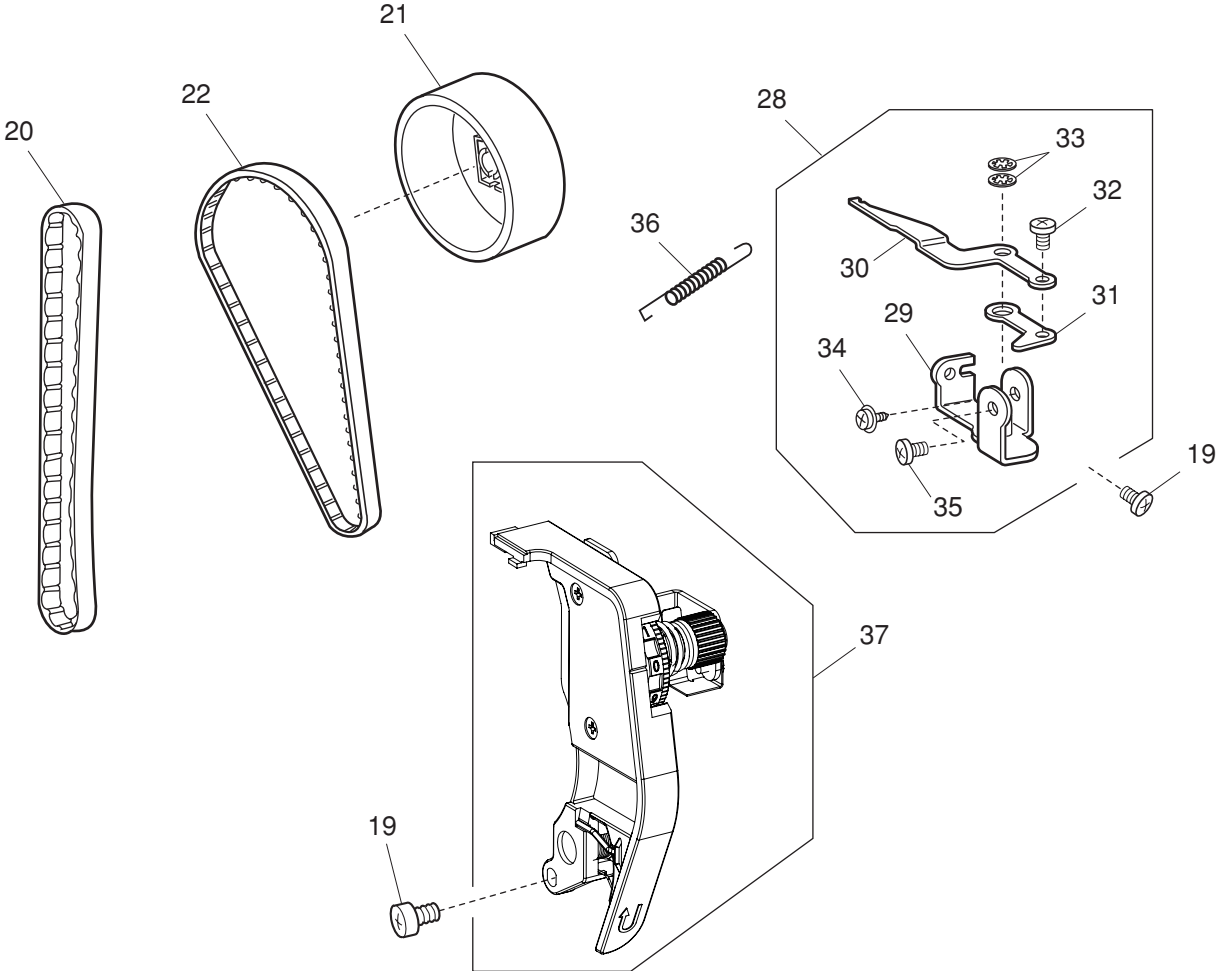
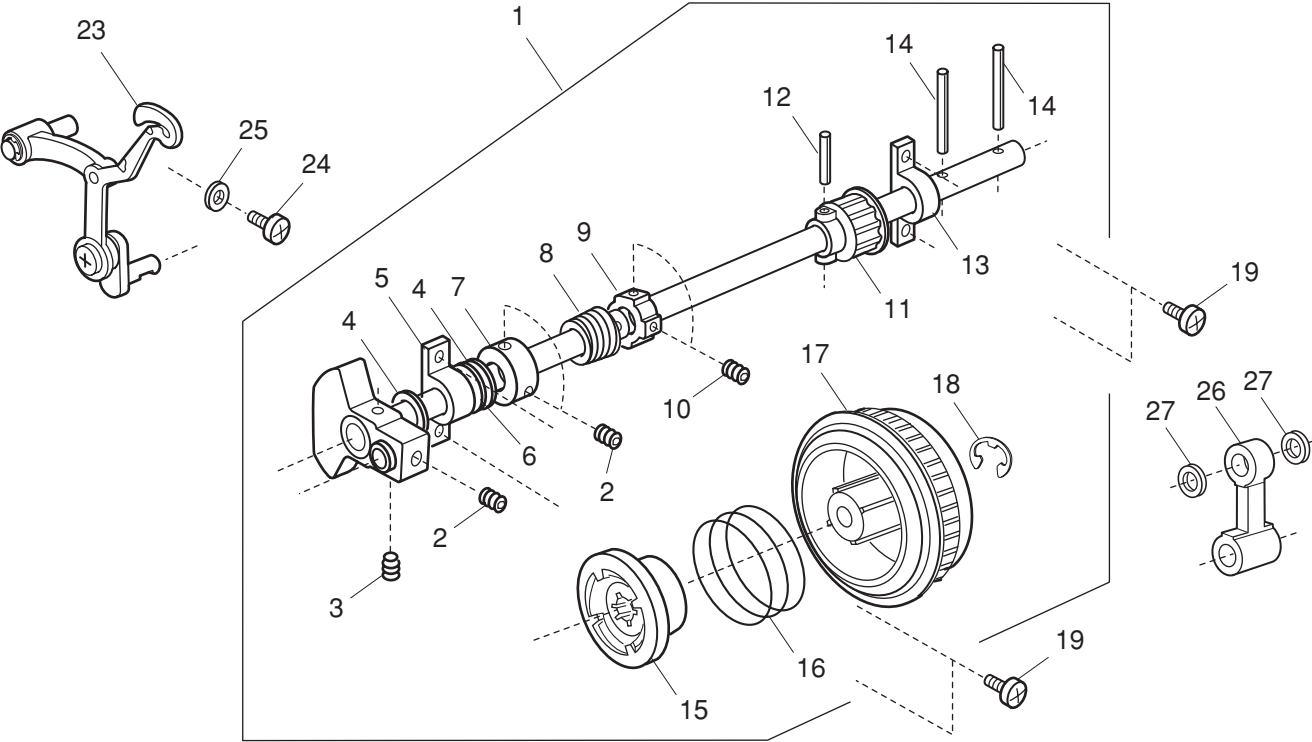

PARTS LIST

KEY NO.	PARTS NO.	DESCRIPTION
1	508603008	Upper shaft (unit)
2	000111201	Hexagonal socket screw 4x4
3	000112800	Hexagonal socket screw 4x6
4	000036201	Washer FT80
5	508120006	Shaft fixing metal
6	823110010	Felt
7	820166001	Lower shaft ring
8	508019001	Worm
9	508020005	Ring
10	000111108	Hexagonal socket screw 4x6
11	508021006	Upper shaft gear
12	000004200	Spring pin 3x18
13	508054101	Shaft fixing metal
14	000024206	Spring pin 3x30
15	502064003	Clutch ring
16	661024007	Clutch spring
17	508055009	Belt wheel
18	000002806	Snap ring E-6
19	000081005	Setscrew 4x8
20	508022007	Syncro belt
21	508056000	Handwheel
22	753234011	Timing belt
23	508601006	Thread take-up lever (unit)
24	000103509	Setscrew 4x10
25	000072302	Washer 4
26	508017009	Needle bar crank rod
27	000036005	Washer FT60
28	508617005	Thread tension set plate (unit)
29	508051005	Thread tension set plate
30	508052006	Thread tension release arm
31	639025009	Thread tension release adjusting arm
32	000103808	Setscrew 3x5
33	000013903	Snap ring CS-5
34	000115205	Setscrew TP 4x6
35	810220003	Setscrew
36	639026000	Thread tension release lever spring
37	508511008	Thread tension (unit)

PARTS LIST

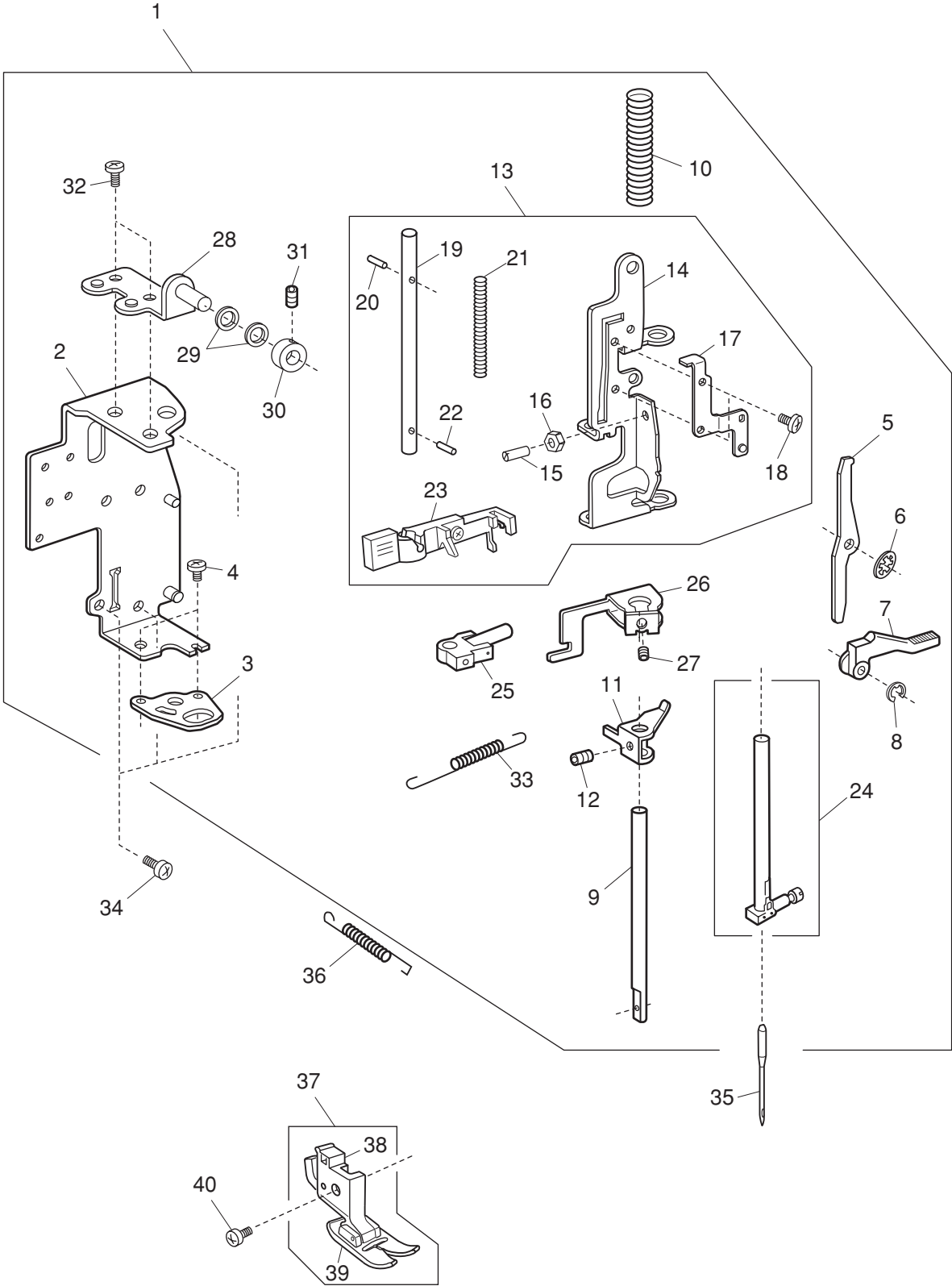

PARTS LIST

KEY NO.	PARTS NO.	DESCRIPTION
1	508640007	Presser bar base plate (unit)
2	508036004	Presser bar base plate
3	508037005	Needle drop adjusting plate
4	000101507	Setscrew 3.5x5
5	508040001	Thread tension release lever
6	000013903	Snap ring CS-5
7	735029004	Presser foot lifter
8	000001609	Snap ring E-5
9	508002001	Presser bar
10	508038006	Presser bar spring
11	508039007	Presser bar supporter
12	000111500	Hexagonal socket screw 4x8
13	508641008	Needle threader (unit)
14	508041002	Needle bar supporter
15	648010009	Setscrew
16	000160102	Adjustable lock nut 4
17	660065007	Zigzag width rod guide
18	000101105	Setscrew 3x4
19	660100201	Threader shaft
20	000122906	Pin E-2x14
21	806040004	Threader spring
22	000003508	Spring pin 2x8
23	639643009	Needle threader plate (unit)
24	508607002	Needle bar (unit)
25	508509003	Needle bar connecting stud (unit)
26	808011002	Threader position set plate
27	000111902	Hexagonal socket screw 3x4
28	660068000	Supporter adjusting plate
29	000036500	Washer FT60 t=0.5
30	650136009	Ring
31	000111201	Hexagonal socket screw 4x4
32	000101404	Setscrew 4x6
33	639110002	Needle bar supporter spring 2
34	000081005	Setscrew 4x8
35	102408089	Needle HA1-14
36	639017008	Needle bar supporter spring
37	660508007	Presser foot (unit)
38	660806008	Presser foot holder (unit)
39	685502019	Zigzag foot (unit)
40	660106001	Setscrew

PARTS LIST

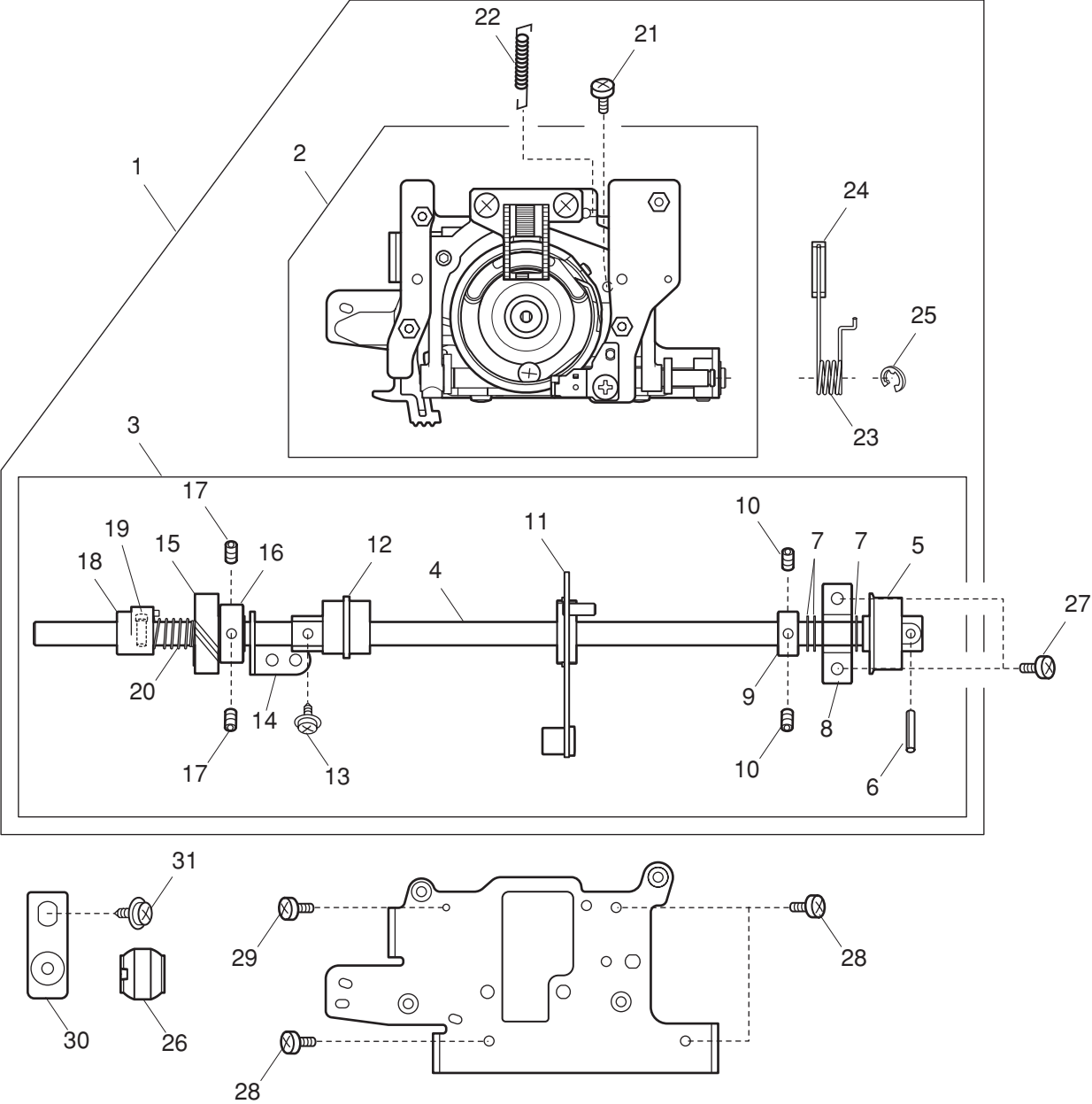

PARTS LIST

KEY NO.	PARTS NO.	DESCRIPTION
1	508636103	Hook race (whole unit)
2	508650000	Hook race (unit)
3	508611102	Lower shaft (unit)
4	508058002	Lower shaft
5	508021006	Upper shaft gear
6	000004200	Knock pin 3x18
7	000038502	Washer
8	508054101	Shaft fixing metal
9	820166001	Lower shaft ring
10	000111201	Hexagonal socket screw 4x4
11	508610008	Feed fork (unit)
12	508200001	Feed cam
13	000115009	Setscrew TP 3x8
14	508098004	Lower shaft supporter plate
15	808110002	Lower gear
16	508020005	Ring
17	000111108	Hexagonal socket screw 4x6
18	503165008	Feed lifting cam
19	820161006	Feed lifting pin
20	508113006	Feed lifting cam spring
21	000103705	Setscrew 4x5
22	508063000	Feed base spring
23	508065002	Feed fork spring
24	751152018	Feed fork spring plate
25	000002507	Snap ring E-4
26	732034003	Lower shaft bushing
27	000081005	Setscrew 4x8
28	000101703	Setscrew 4x12
29	000081500	Setscrew 3x12
30	502204007	Lower shaft bushing set plate
31	000115504	Setscrew TP 5x10

PARTS LIST

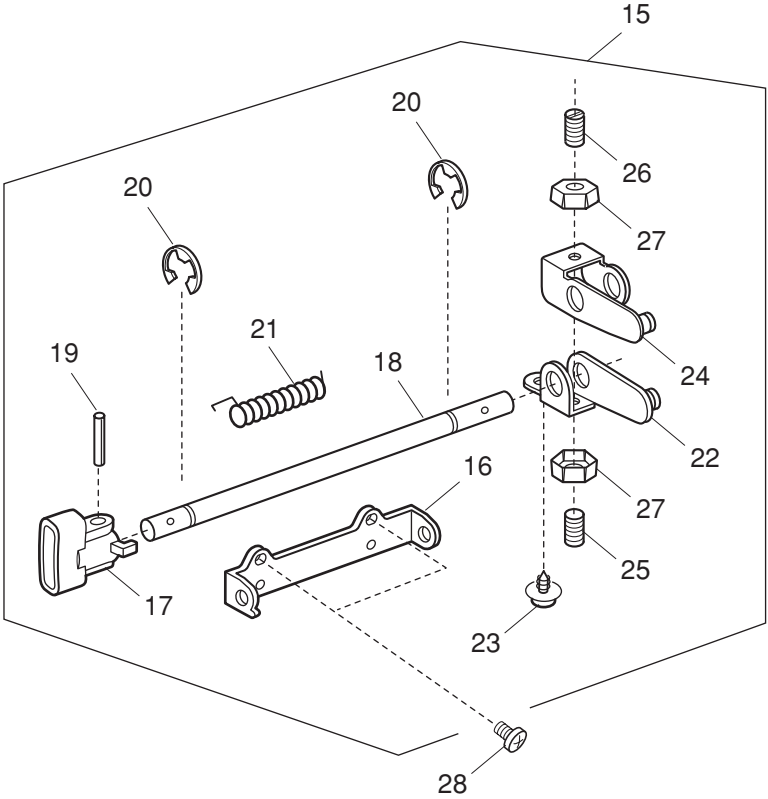
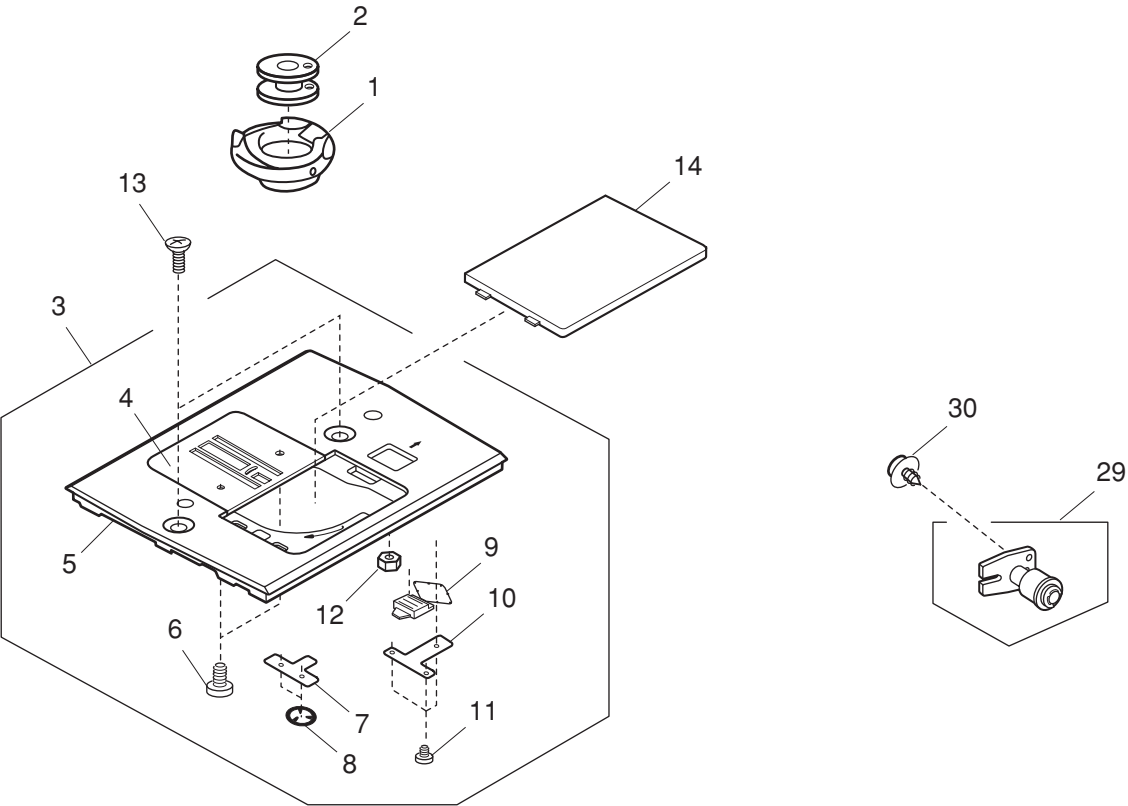

PARTS LIST

KEY NO.	PARTS NO.	DESCRIPTION
1	627569106	Bobbin holder (unit)
2	102261000	Bobbin
3	508612000	Needle plate (unit)
4	508033104	Needle plate
5	508034002	Support needle plate
6	000163703	Setscrew 2x3.5
7	502015009	Spring
8	000015503	Snap ring CS-2.4
9	502016000	Hook cover plate release button
10	502202005	Supporter plate
11	000130206	Setscrew 1.7x2.5 (B)
12	508116009	Nut
13	820390109	Setscrew
14	846271103	Hook cover plate
15	508613001	Feed regulator (unit)
16	508095001	Feed regulator shaft supporter
17	508067004	Feed regulator
18	508068005	Feed regulator shaft
19	000005108	Spring pin 2x18
20	000001609	Snap ring E-5
21	508069006	Feed regulator spring
22	508070000	Feed shaft set plate
23	000115906	Setscrew TP 3x12
24	508071001	Feed regulating plate
25	648010009	Setscrew
26	000159201	Setscrew 4x12
27	000160102	Adjustable lock nut 4
28	000081005	Setscrew 4x8
29	508614002	Idler (unit)
30	000115607	Setscrew TP 4x8

PARTS LIST

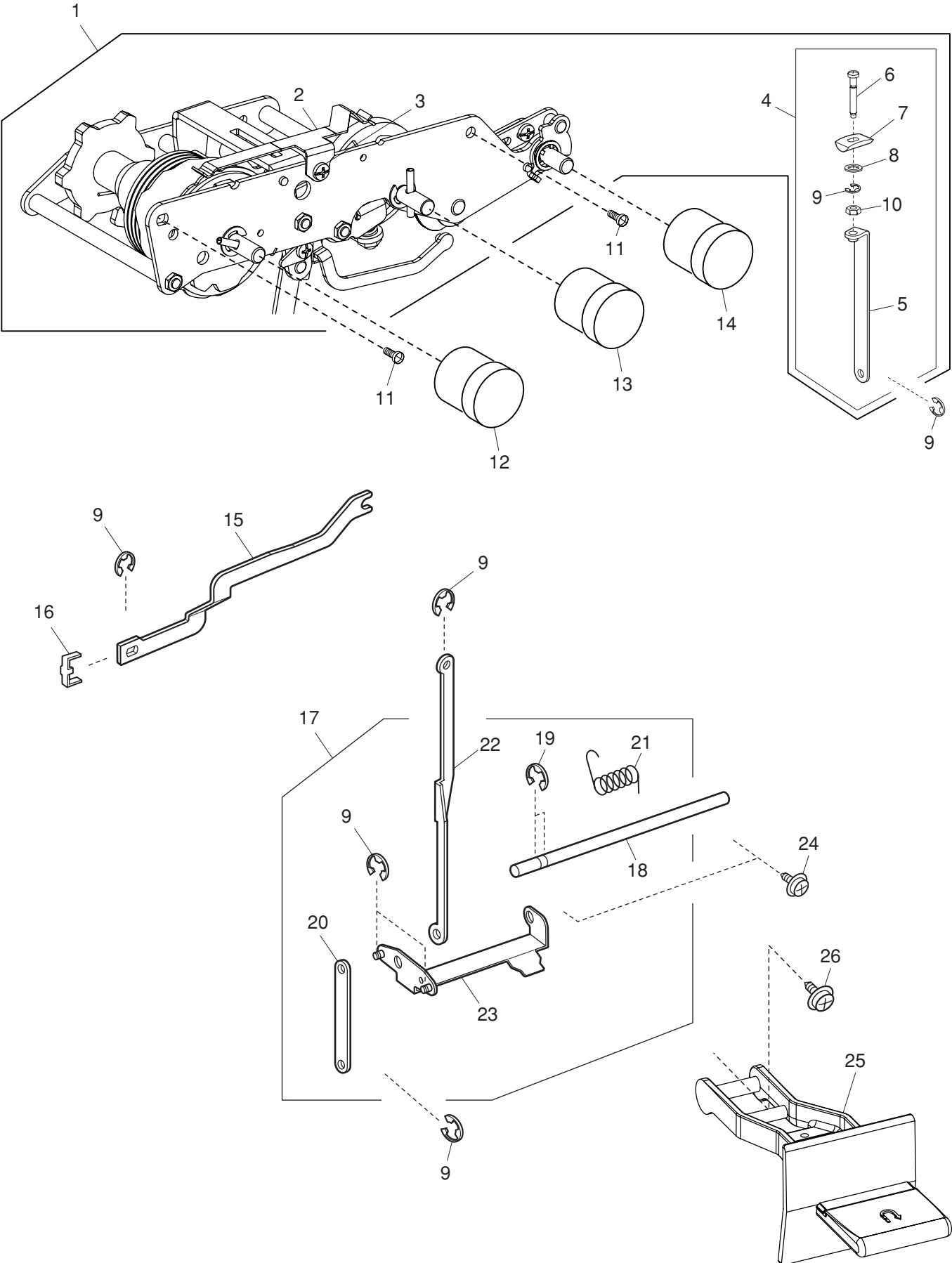

PARTS LIST

KEY NO.	PARTS NO.	DESCRIPTION
1	508642009	Cam block (unit)
2	737011009	Index spring
3	000103808	Setscrew 3x5
4	508637001	SS rod (unit)
5	508086009	SS rod
6	735074004	Adjusting screw
7	735076006	SS rod block
8	000071013	Washer 4
9	000002105	Snap ring E-3
10	000160102	Adjustable lock nut 4
11	000081005	Setscrew 4x8
12	508130A07	Pattern selector dial
13	508130A10	Stitch length dial
14	508130A09	Zigzag width dial
15	508089002	Zigzag width rod
16	639098003	Zigzag width rod back plate
17	508616200	Reverse stitch shaft (unit)
18	508099005	Reverse stitch shaft
19	000001609	Snap ring E-5
20	508101001	Feed link
21	508049000	Reverse lever spring
22	508087000	Feed rod (1)
23	508106006	Feed rod (2)
24	000115700	Setscrew TP 4x10
25	508126002	Reverse lever
26	000119106	Setscrew TP 4x10

PARTS LIST

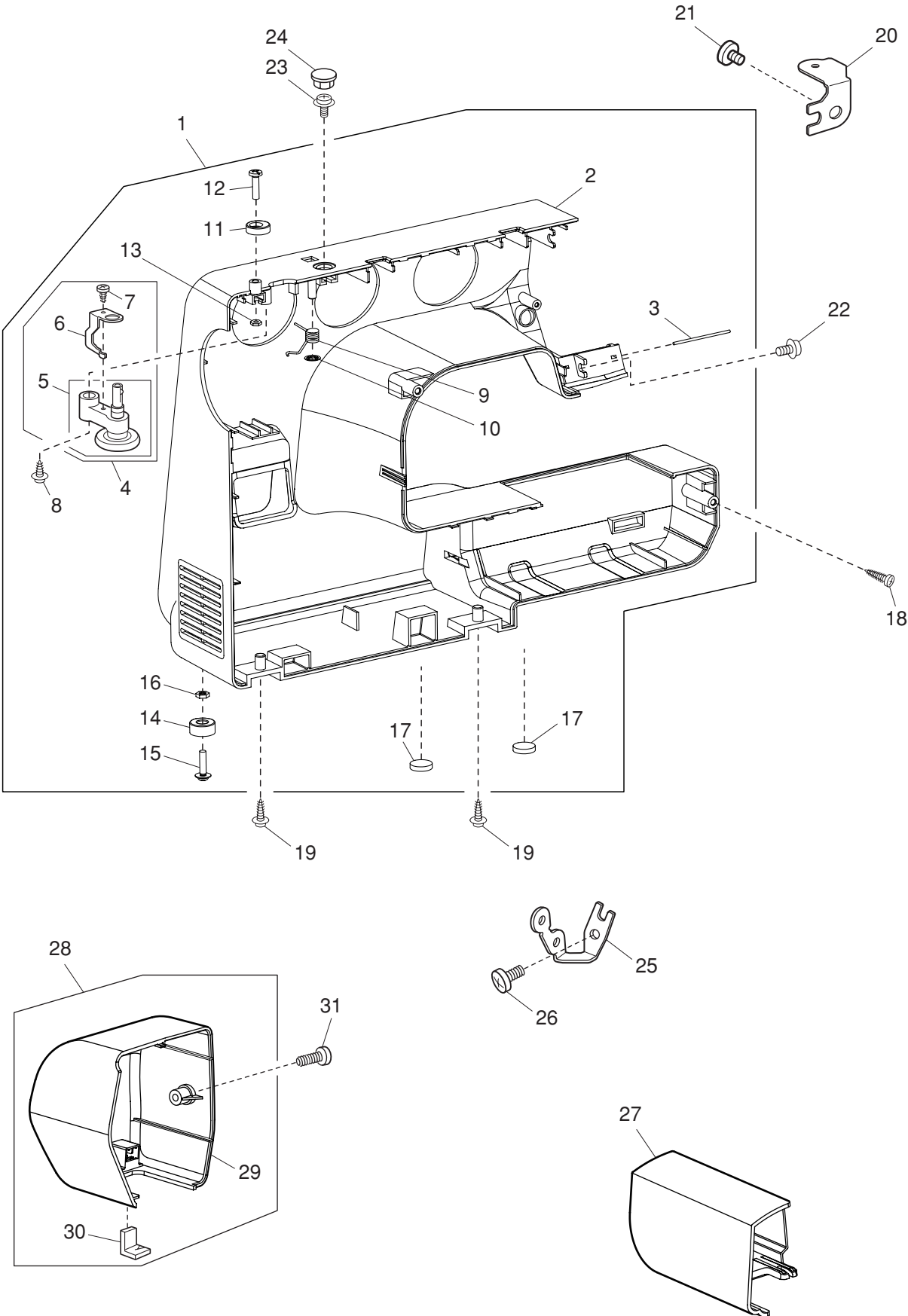

PARTS LIST

KEY NO.	PARTS NO.	DESCRIPTION
1	508643099	Front cover (unit)
2	508128A04	Front cover
3	639075004	Thread guide
4	508620001	Bobbin winder (unit)
5	508507001	Bobbin winder arm (unit)
6	508111004	Clutch lever
7	000120203	Setscrew 3x8 (B)
8	000109103	Setscrew 4x12
9	508030008	Spring
10	000013903	Snap ring CS-5
11	735016307	Bobbin winder stopper
12	000101828	Setscrew 4x16
13	000061205	Nut 4-3-7
14	639005003	Rubber foot
15	000201405	Setscrew TP 4x16
16	000160102	Adjustable lock nut 4
17	525010005	Rubber foot
18	000108308	Setscrew 4x20
19	000161310	Setscrew 3x12 (B)
20	508093009	Front cover set plate
21	000101404	Setscrew 4x6
22	000115205	Setscrew TP 4x6
23	000114709	Setscrew TP 3x6
24	653006101	Cap
25	639080002	Front cover set plate
26	000081005	Setscrew 4x8
27	508131000	Extension table
28	508644506	Face plate (unit)
29	508132A02	Face plate
30	840602006	Thread cutter (unit)
31	000104119	Setscrew 4x20

PARTS LIST

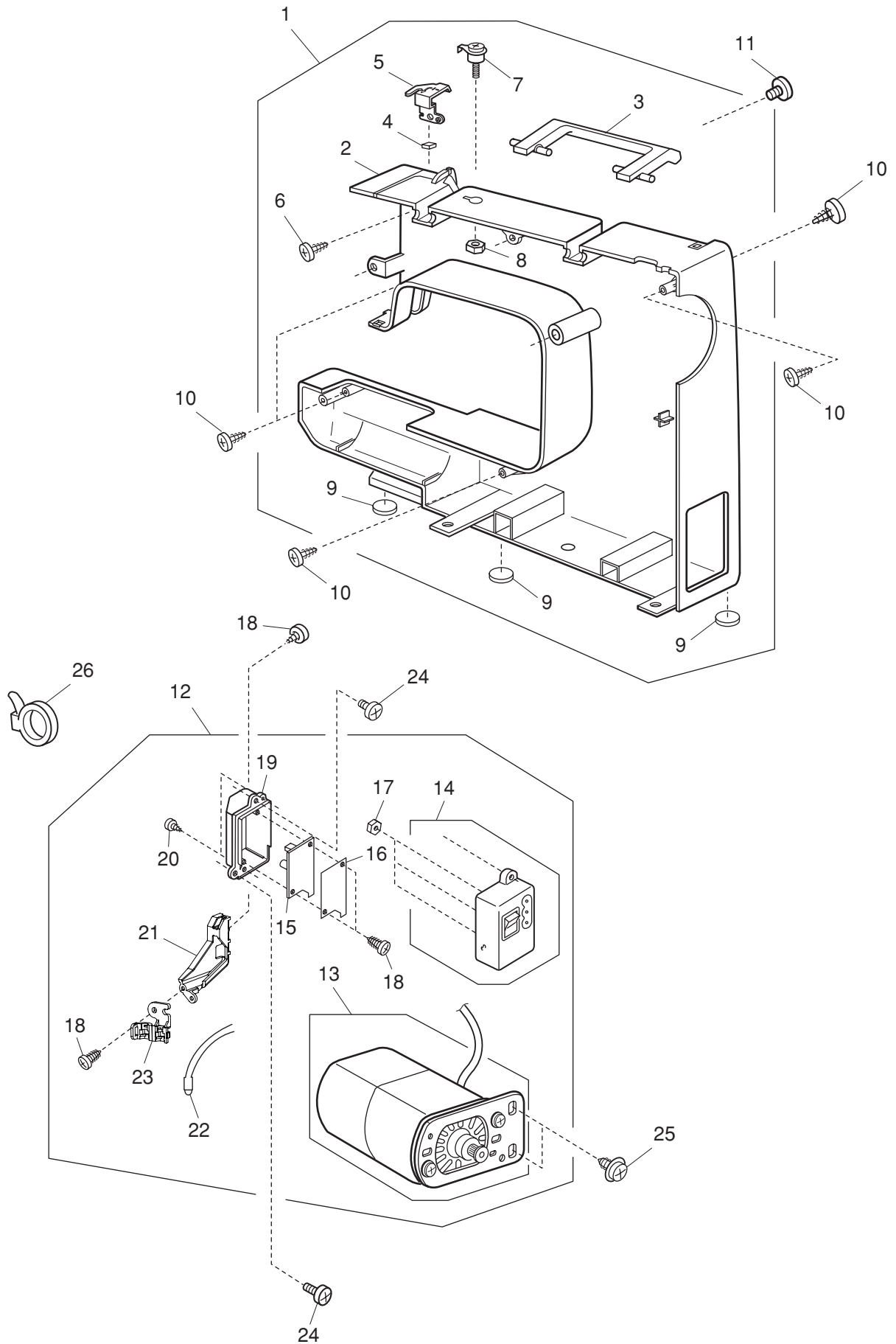

PARTS LIST

KEY NO.	PARTS NO.	DESCRIPTION
1	508618051	Rear cover (unit)
2	508027A02	Rear cover
3	508028003	Carrying handle
4	660077002	Felt
5	660618001	Threader guide plate (unit)
6	000107307	Setscrew 3x6 (B)
7	730501011	Threader guide plate (unit)
8	000160102	Adjustable lock nut 4
9	525010005	Rubber foot
10	000161310	Setscrew 3x12 (B)
11	000081005	Setscrew 4x8
12	508646003	Machine socket (unit)
13	508648005	Motor (unit)
14	739503308	Machine socket (unit)
15	508512009	Printed circuit board C (unit)
16	508134003	Flame retardant insulating paper
17	000060802	Nut 3-1-5.5
18	000120203	Setscrew 3x8 (B)
19	508133002	Machine socket cover
20	000107802	Setscrew 3x10 (B)
21	508135004	LED set arm
22	508515002	LED (unit)
23	508143005	LED holder
24	000103509	Setscrew 4x10
25	000115504	Setscrew TP 5x10
26	000053008	Cord binder

PARTS LIST

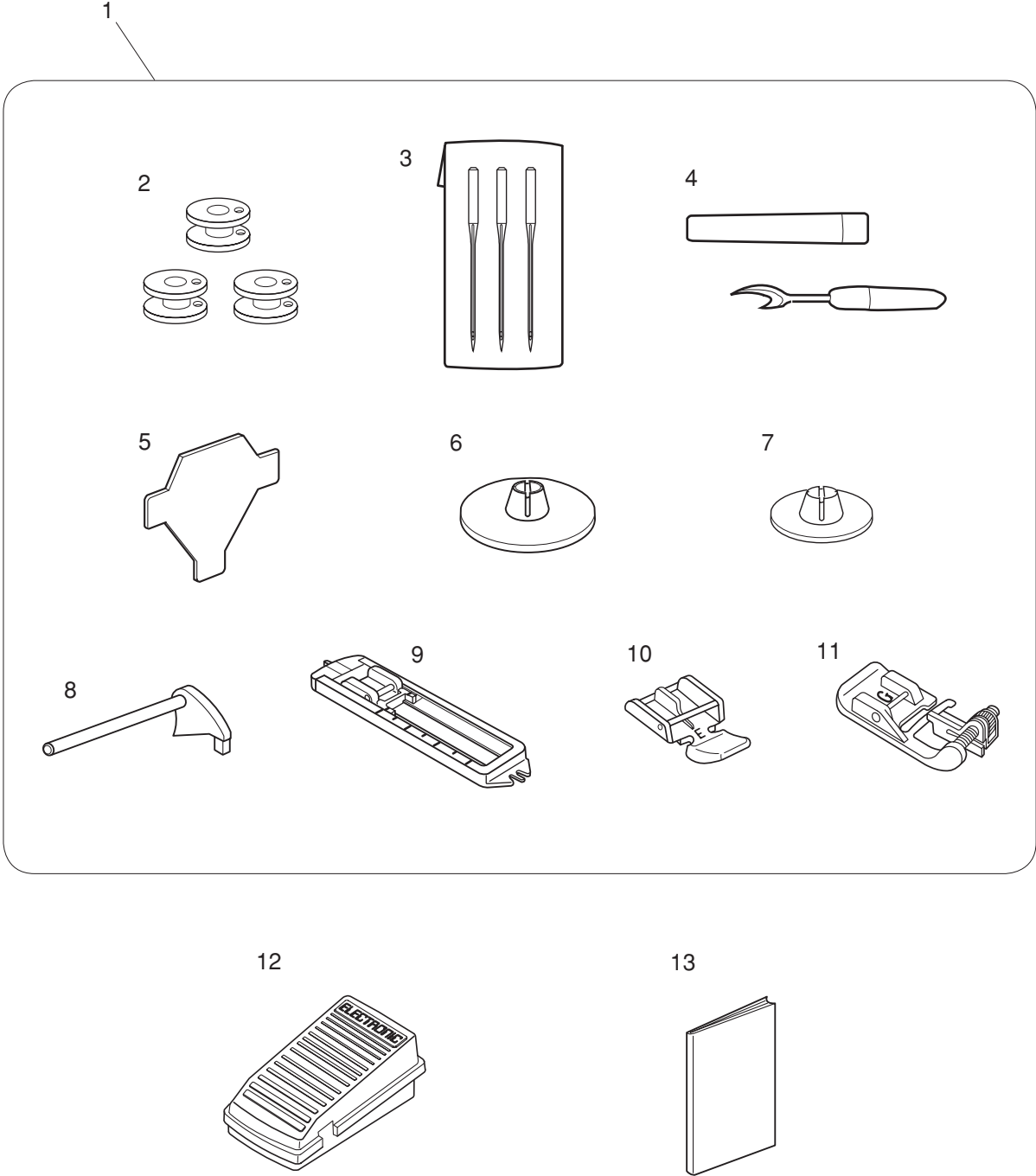

PARTS LIST

KEY NO.	PARTS NO.	DESCRIPTION
1	508870101	Accessory set
2	102261000	Bobbin
3	639804000	Needle set (unit)
4	647808009	Seam ripper
5	653802002	Screwdriver
6	822020503	Large spool holder
7	822019509	Small spool holder
8	625031500	Additional spool pin
9	508803000	Buttonhole foot
10	829801002	Zipper foot
11	820817015	Blind hem foot
12	045501005	Foot control
13	508800742	Instruction book
